

ENGLISH

TORQUEEDO

SERRY
JACHTWERF

Oud-Loosdr. dijk 249 a-d
1231 LX Loosdrecht
Holland
Tel. 035-58 234 04
Fax 035-58 260 80
info@serry.com
www.serry.com

Electric Boating 2017



*Winner of the
DAME Award 2016:
Cruise FP Models*

Accelerating sustainable mobility

- 2 steps forward in 2017

Torqueedo stands for clean, sustainable mobility on the water. In 2017, we are making two important steps that will advance electric and hybrid propulsion in boating.

1 In the sailing world, quiet discussions have been occurring for a while that the days of the classic diesel inboard might be coming to an end. We believe, a few years from now, 2017 will be seen as a time when this process really started.

Torqueedo pod motors in combination with our batteries, throttles, and user interface provide a true alternative to diesel inboards. The system is extremely lightweight, can act as a hydro-generator and create power while sailing, and is competitive in cost. As a consequence, one of the leading large-scale sailboat manufacturers is offering electric propulsion as a real alternative to a diesel inboard. Find out who it is on page 40.

Along our entire product range, Torqueedo now offers compelling solutions for sailors from small sailing dinghies up to 80 ft luxury yachts.

2 The second highlight is from our Deep Blue series. **In cooperation with BMW i, Torqueedo now brings the very latest in automotive battery technology to boating.** The BMW i3 battery has been adapted to work flawlessly with our Deep Blue system, offering 40% higher energy density than before at lower cost. Find out why we feel that this battery is in a league of its own when it comes to battery technology for marine applications on page 18.

In addition, we have improved Deep Blue's user interface, applying state-of-the-art displays and design and a new throttle family.

You may notice that we have changed our logo for 2017. Out of the 11 years of our history, 10 years were dedicated to internationalization. Today, our team consists of more than 100 people from 15 nationalities and extends worldwide through our network of partners to customers in over 50 countries. Even though research and manufacturing remain located largely in Germany, we felt it was time to reflect our international character and focus.

SERRY
JACHTWERF

Oud-Loosdr. dijk 249 a-d
1231 LX Loosdrecht
Holland
Tel. 035-58 234 04
Fax 035-58 260 80
info@serry.com
www.serry.com



10 Why Torqeedo

10 Clean mobility

12 Overall efficiency

14 Drive technology

16 Battery technology

20 Electric outboards and pod drives

≅ 1 - 20 HP

22 Ultralight 403

≅ 1 HP

26 Travel 503/1003/1003 C **NEW**

≅ 1.5 - 3 HP

32 Cruise 2.0/4.0/10.0 Outboards

≅ 5 - 20 HP

36 Cruise 2.0/4.0/10.0 Pod drives

≅ 5 - 20 HP

48 Power 26-104

52 High-voltage drive systems

≅ 40 - 160 HP

54 Deep Blue

≅ 40 - 80 HP

62 Deep Blue Hybrid

≅ 40 - 160 HP

68 Information

68 Technical specifications

71 Ordering information

74 Contacts

News



Travel 1003 C

- _ 73 % greater battery capacity
- _ Minimum weight - maximum energy density

Page 26



Electronic throttle

- _ For all Cruise and Deep Blue models
- _ Clean, modern appearance, high-quality, functional

Page 42



On-board computer

- _ Marries informative, functional data with high resolution marine displays and clean aesthetics
- _ Clearly arranged information
- _ For Deep Blue and Cruise motor systems

Page 43



Deep Blue with BMW i battery

- _ Leading edge automotive technology
- _ Fully integrated into Deep Blue / Deep Blue Hybrid
- _ 40% higher energy density
- _ Highest standards of quality and safety

Page 18



25 kW range extender

- _ DC inverter-generator
- _ Efficient generation of power at various loads and at various voltage levels
- _ Quiet and lightweight

Page 67



Join the discussion!
<https://www.facebook.com/torqueedo>

Boating the contemporary way

Torqeedo transforms your marine leisure activity into modern, clean and safe enjoyment. Our motors are leading-edge, high-tech design products powered by the safest and most powerful lithium batteries of their kind.

Please come aboard ...

- Simple handling
- Clean to use: no smells, no leaks, no fuel
- Many convenient features
- Avoid significant harmful pollutant emissions
- Modern design
- Low noise level
- Highest safety level



Queen Elizabeth Dr
OTTAWA



Electric workboats – a decision that pays off

- Save 100% of your petrol or diesel costs
- + Instead, spend a fraction of saved costs on electricity and battery write-off
- + Reduce maintenance costs
- + Enjoy high reliability

= If you are out on the water 100 days a year or more, you may save money by going electric.

... and protecting our waters and atmosphere is a bonus.

It all adds up with Torqueedo ...



Deep Blue high-voltage drives

Our 80 HP models from the Deep Blue series can save you money if your annual petrol or diesel bills exceed EUR 4,500. Find out more on page 61.



Cruise motors

In the power class up to 20 HP, our Cruise drive systems can reduce costs if your annual petrol or diesel costs exceed EUR 1,000. Find out more on page 32.

What does a 5 HP petrol outboard have in common with 38 cars?

Internal combustion engines discharge a number of harmful substances, including carbon dioxide (CO₂), nitrogen oxide (NO_x), hydrocarbons (HC) and particulate matter. Imagine you are running a new 5 HP four-stroke outboard for one hour. Would you suspect that you are producing the same amount of NO_x and HC pollution as if you were driving 38 new cars at 95 km/h for the same length of time?

Let's look at the facts.

The automotive industry uses sophisticated methods to avoid nitrogen oxides and hydrocarbons during the combustion process, and then uses exhaust aftertreatment to further reduce them. Standard methods include electronic engine control, exhaust gas recirculation and catalytic converters, which have been required equipment in automobiles for around 30 years.

Outboards do not have any comparable systems – not even the very latest models. This is why the level of harmful nitrogen oxide and hydrocarbon emissions, even from very small petrol outboards, is dramatically higher than in cars. Though there are far fewer outboards than cars, their pollution is substantial and vastly out of proportion.

Nitrogen oxides and hydrocarbons are poisonous, carcinogenic, and contribute to the formation of ozone and acid rain.

If you can avoid these high levels of emissions by switching to quiet, modern and emission-free electric drive systems – then why wouldn't you?

Emission asymmetries in numbers:

Running a 5 HP four-stroke outboard at full power for one hour produces the same NO_x and HC emissions as running 38.5 new cars at 95 km/h for the same period.

Official emission standards confirm that dramatically higher nitrogen oxide and hydrocarbon pollution emissions are permitted for outboard motors.

Even small 5 HP outboards may produce up to 22 times the NO₂ and HC emissions compared to a passenger car

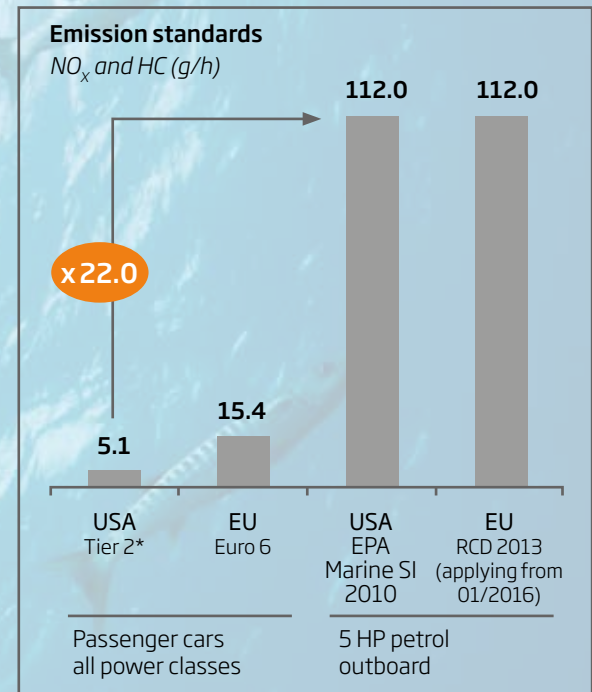
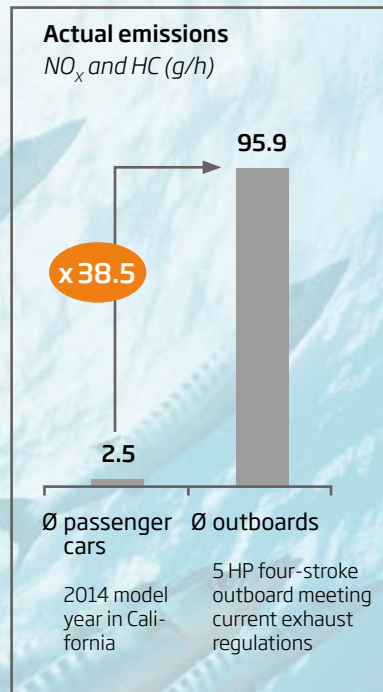

In this comparison, cars move significantly faster than small outboards. Outboards would perform even worse if we looked at emissions per kilometre rather than per hour. More powerful outboards are relatively more efficient than smaller outboards, i.e. they emit fewer harmful substances per HP. In absolute terms, however, there pollutant emissions are far greater than those of small outboards and would perform significantly worse in these comparisons.

* US passenger car emissions refer to (non-methane organic gases) plus NO_x, not to HC plus NO_x.
Sources: United States Environmental Protection Agency, California Air Resources Board, Environmental Capital Group

Advantage Torqeedo

1 HP is 1 HP. Isn't it?

Standardisation of power is nothing new. It all goes back to James Watt, who defined horsepower in the 18th century to demonstrate the performance of his steam engine. Since then, it's been measured uniformly in HP or, in honour of its inventor, in watts. And with that, everything should be clear. Shouldn't it? Not quite, because it depends on where and how you measure.

The **most meaningful performance indicator** of a drive system is **propulsive power**, which indicates the performance actually delivered by the motor to move the boat, taking all losses, including propeller loss, into account. This method has been used in commercial shipping for nearly 100 years.

For petrol and conventional electric outboard motors the propulsive power is not normally disclosed. Instead, less meaningful indicators are used such as **shaft power**, **input power** or even **static thrust**.

That wouldn't be so bad if the differences between the various power ratings were minimal. However, the opposite is the case. The propulsive power of a petrol outboard with 4 HP shaft power, for example, is just 1 HP. How can the differences in efficiency levels of different types of motor be measured? We'll shed some light on them.



Shaft power: Power rating of petrol outboards, comparable with passenger cars (torque x angular velocity). The rating is expressed in HP or kW but does not take propeller loss into account, which can vary by anywhere between 20% and 75%.

Superior propulsion and superior overall performance

Our focus on optimising propulsive power and our use of the latest technologies means Torqeedo has the highest overall efficiency on the market. Every Torqeedo drive converts the available battery power to propulsive power better than any other outboard. This is very important for electric drives with limited battery capacity because it means more power and range.

Overall efficiency levels of various outboards

Input power: A drive's power consumption. Often used as a performance indicator for electric outboards (current x voltage), expressed in watts or HP. Does not take system loss into account.

Propulsive power: Performance indicator used by commercial shipping and Torqeedo (thrust x speed). The rating is expressed in HP or kW and takes all losses into account, including propeller loss, and clearly indicates the actual power delivered by the drive system for propulsion.

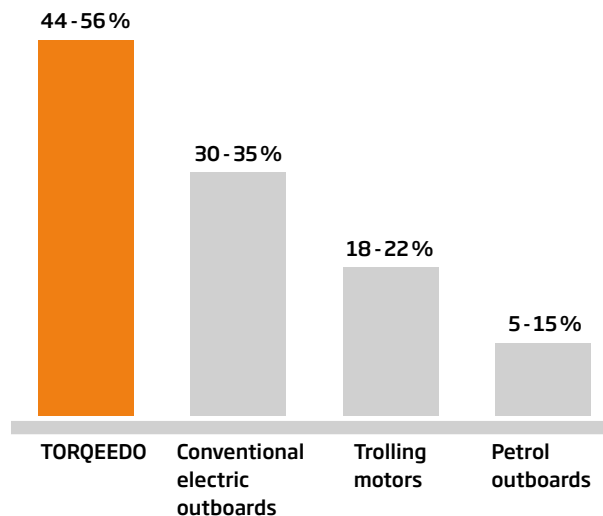

Comparing the power of electric and combustion outboards: Torqeedo's HP Equivalent

Electric motors can achieve the same propulsive power as combustion engines with significantly lower shaft power. The reason lies in the different torque curves of electric motors and gasoline or propane engines: While the torque curve of combustion engines features a prominent peak, with maximum torque available only in a limited working point, electric motors feature a much flatter torque curve, with ample torque available at any rotational speed. This characteristic allows them to run propellers with substantially higher efficiencies than combustion engines. Propeller efficiencies in the lower horsepower class can vary by a factor of 3 between combustion outboards and Torqeedo electric outboards.

To make the comparison easy for boaters who are used to shaft power ratings of gas outboards, we always compare the actual propulsive power of our outboards versus gas or propane outboards. On the following pages, a Torqeedo outboard specified as a "3 HP equivalent", provides the same propulsive power as a 3 HP combustion outboard - even though its shaft power and input power may be substantially lower.

In the Technical Data section of this catalog, we provide all information on input power, propulsive power, overall efficiency and comparable gas or propane outboards for your reference.

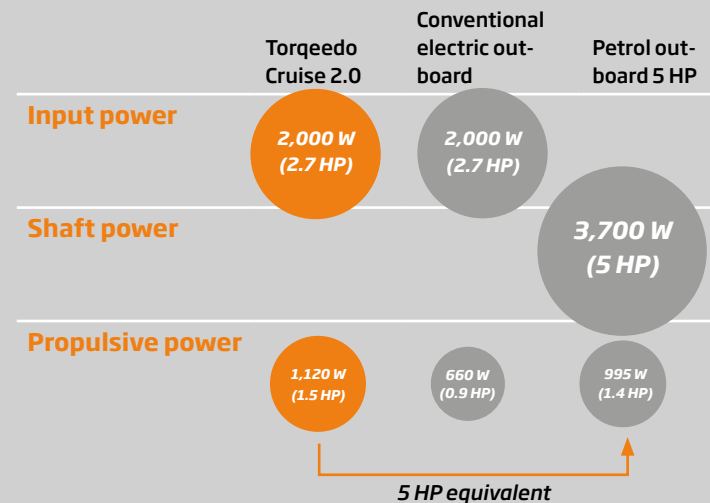

Designed for power

Inner strength – Torqeedo power train engineering

Torqeedo drives convert limited battery capacity into more propulsive power than any other outboards. This is very important for electric drive systems in particular as it means more power and greater range with the same battery capacity.

Superior propulsive power and overall efficiency don't just fall out of the sky. They come from inhouse development that uses the latest technologies in power-train engineering and uncompromising optimisation of every component. We carefully match all components of the drive train for performance, focusing on tailored solutions and industrial engineering.

Efficiency and power – Torqeedo motor technology

Superior motor technology is at the heart of all Torqeedo drives. From the very beginning of the company, we have only constructed **brushless, electronically commutated motors** with **rare-earth magnets**. Motors and electronics are developed for ultimate efficiency over the entire RPM range and for superior power densities.

That is why our motors are typically lighter and smaller than other motors of the same power class.

Motor optimisation always depends on the application, which is why **Torqeedo motors are always tailored** in terms of form, motor speed and torque. Torqeedo motor design and the right choice of propeller makes it easier to cater to a wide range of requirements. The torque requirements of a boat motor are significantly different from those of a land vehicle. While motors for land vehicles are optimised to provide maximum torque in the low load range for quick acceleration, the exact opposite applies to boat drive systems. Here it is all about moving a propeller as slowly and as powerfully as possible. Boat drives therefore need their maximum torque in the highest performance range. This, too, is the main reason why we rely exclusively on **in-house high-tech development** at Torqeedo.

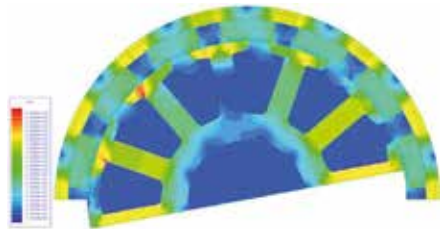

Simulation of magnetic field distribution for optimising the design of a motor (structure, magnet geometry, air gap, plate cross-section and rotor design)

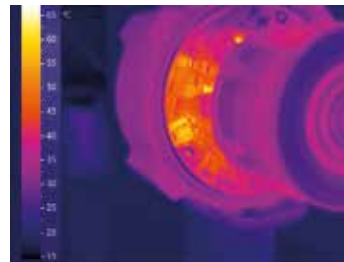

Simulation of thermal load of the motor electronics

Carefully selected gears for optimum torque and speed

Propellers are at their most efficient when they are moved slowly but powerfully (high torque, low rotational speed). This is achieved by the use of **planetary gears** for minimum weight and volume. Torqeedo uses only the highest quality gears from German precision production. They are extremely efficient and have an impressive **service life of up to 50,000 hours**.

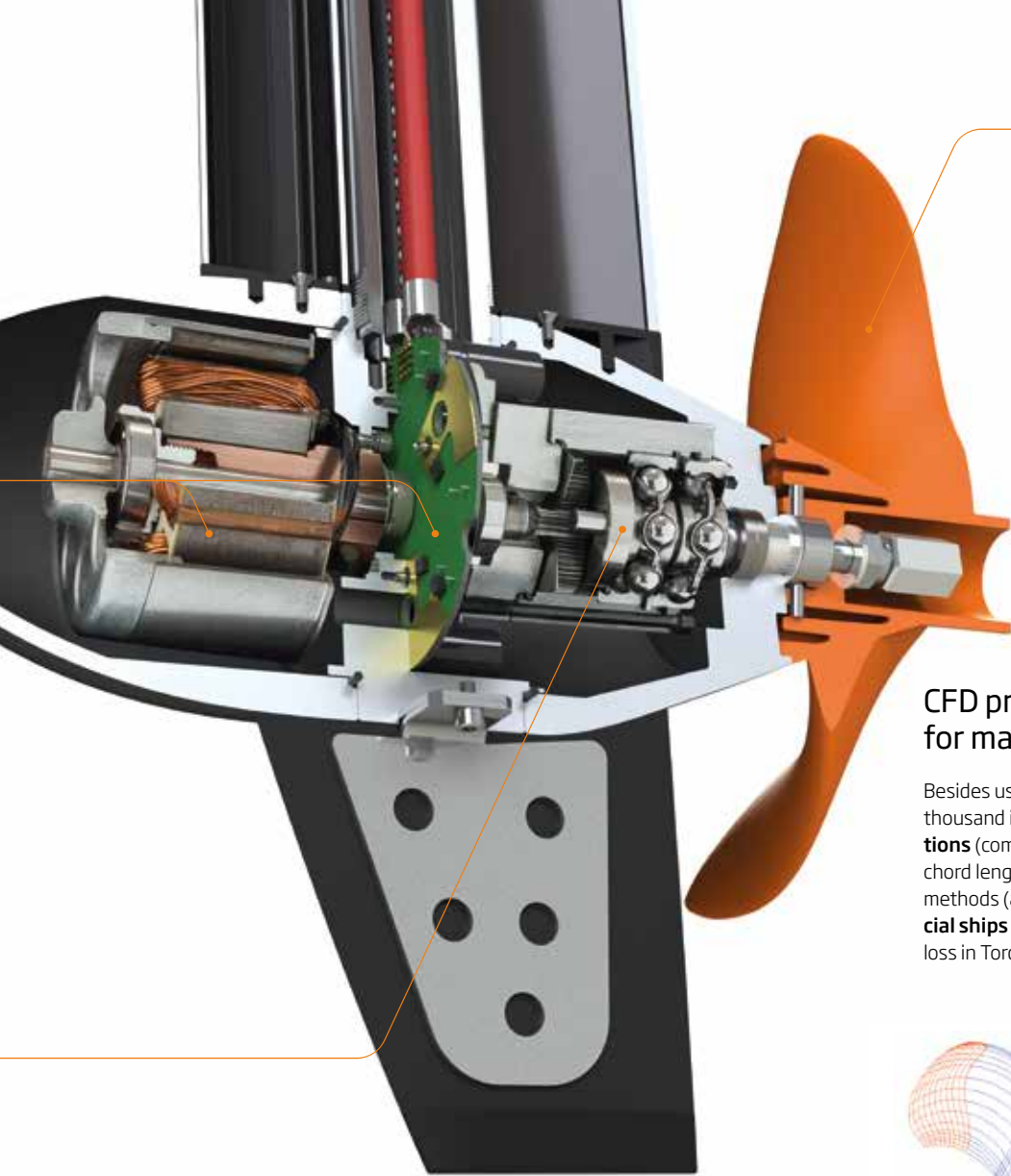

Conventional propeller optimisation – exploiting the outstanding torque characteristics of Torqeedo motors

There are dramatic differences in propeller efficiencies. Poorly designed propellers may deliver only 20% efficiency while outstanding propellers deliver around 75%. There are three main characteristics of an efficient propeller: a large diameter, a high pitch and a slow rotation.

Only motors **with high torque** can drive efficient propellers. Torqeedo motors deliver high torque along their entire rpm range. All Torqeedo propellers are designed to exactly meet the demands of the application and to take full advantage of the **superior torque characteristics** of our motors.

CFD propeller calculations from commercial shipping for maximum efficiency

Besides using conventional optimisation methods, we perfect our propellers over several thousand iterations with the help of **multi-dimensional, fluid mechanic CFD calculations** (computational fluid dynamics). In this process, all propeller parameters – diameter, chord length, pitch, skew, rake, camber and thickness – are calculated using the same methods (and by the same experts) that also define the **the propeller form for commercial ships and submarines**. It is an elaborate but worthwhile method for cutting propeller loss in Torqeedo drive systems to a minimum.

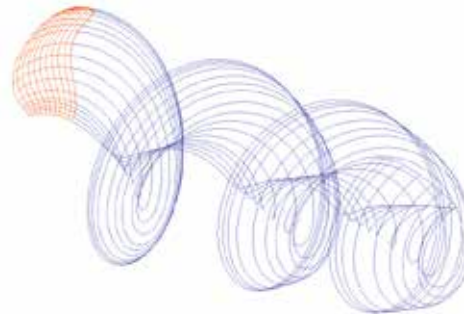

Lattice structure used to calculate the individual characteristics of a custom-made Torqeedo VPVC propeller (variable pitch variable camber)

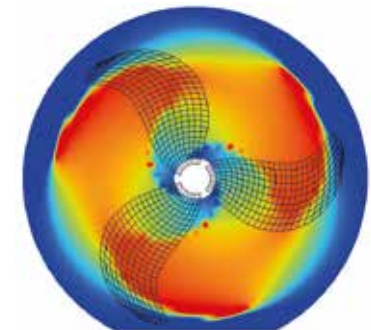

Profile of the calculated slipstream (red: high speeds; blue: low speeds)

Safe performance - designed down to the last detail for the most demanding use

Superior battery technology

Lithium-based batteries are the technology of choice for electric mobility applications. They store significantly more energy than all other batteries, they maintain a high current - a major advantage for electric drive systems - they do not lose their charging capacity, they supply power reliably even in the cold and have no memory effect. They also provide many more cycles than lead-based batteries.

Torqeedo has been a pioneer in the development of lithium batteries for boat applications for ten years. Since we make our batteries just a little bit better each year, we offer the most comprehensive and integrated protection and safety concept for lithium batteries on the market - coupled with performance and convenience.

Intelligent battery management system (BMS)

The BMS **monitors and protects** Torqeedo batteries against overcharging, overcurrent, deep discharge, short-circuit and overheating. The battery has comprehensive safety features, in other words, each safety-relevant component is duplicated with a backup component should it fail. In addition to these safety features, the BMS safeguards the battery's life expectancy with balancing and deep-sleep functionality.

Powerful

Convenient

Safe and easy transport

Thanks to their **high energy density**, the volume and weight of lithium batteries are up to 70% lower than comparable AGM or lead-gel batteries. This makes our low-voltage batteries simple to handle and light to carry. On top of that, Torqeedo Power and Deep Blue batteries can be switched on and off, allowing them to be safely **transported and installed** and protecting them against unintentional discharge.

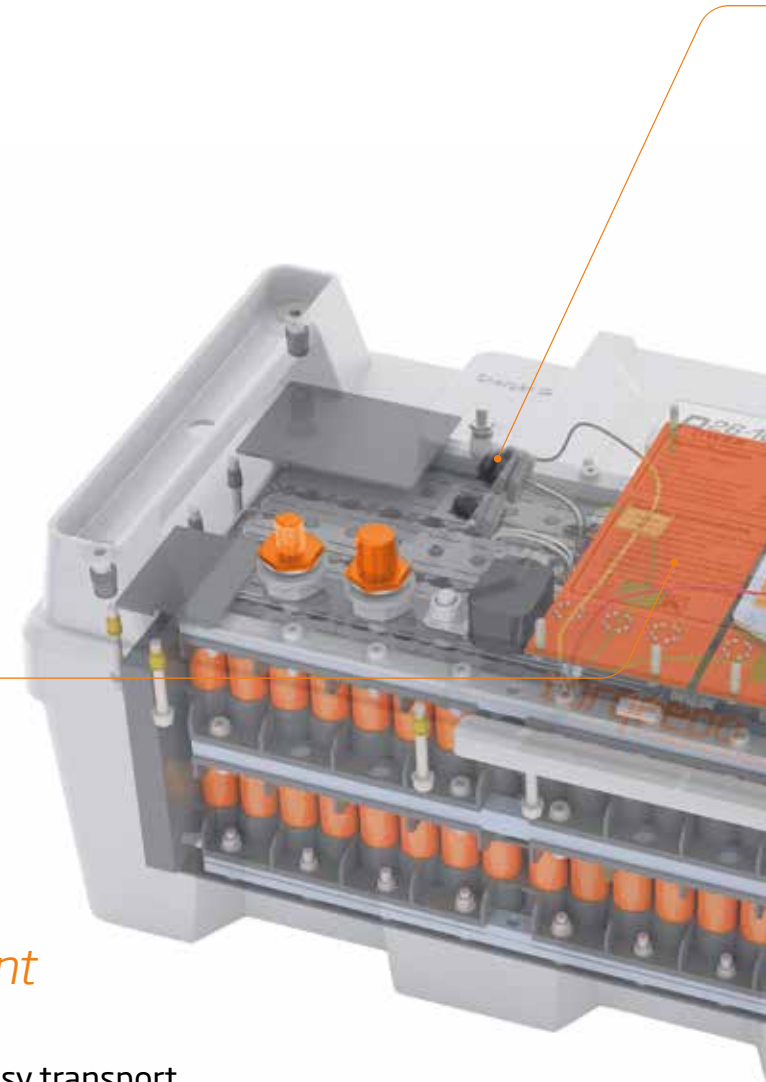

System communications

The battery electronics continuously communicate all the details of the battery status to the on-board computer.

Dependable and efficient

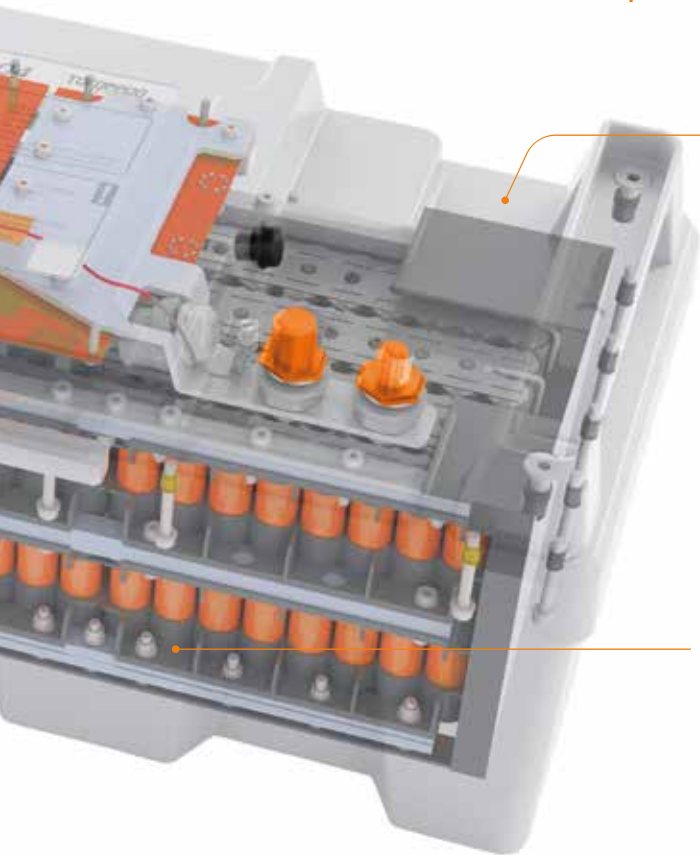

Completely waterproof

Waterproof housing (IP67). While battery immersion should be avoided, all Torqeedo batteries are, without exception, completely waterproof. The waterproof characteristics of each battery are individually tested prior to delivery.

Waterproof data connections. Whether connected or not, all cable connectors are completely waterproof to IP67.

High quality safety cells

Three hardware mechanisms in every single cell provide additional safety. Torqeedo only uses cells based on lithium (Li-NMC) sourced from the **clean, precision production processes** of reputable manufacturers.



Safety of lithium batteries

Besides performance, safety plays an important role for lithium batteries. In our view, five factors need to be considered in order to ensure that safe really means safe:

1. **Safe battery chemical engineering**, e.g. LiFePO (lithium iron phosphate) or LiNMC (lithium nickel manganese cobalt oxide). These are now widely used.
2. **Safe, individual cell packaging:** Torqeedo only uses safety cells - welded steel cylinders equipped with multiple hardware safety mechanisms. Other forms of packaging such as foil-sealed cells (coffee bags) offer a lower standard of safety as they afford less effective protection against short circuiting within the cells. (An exception here are cells with ceramic separators, which also provide safe packaging, but these are extremely expensive and very seldom used.)
3. **Clean, precision production processes** on the part of the cell manufacturers. Torqeedo only uses cells sourced from the most reputable brands in the world.
4. **Battery management system (BMS) with redundant safety features:** unlike lead-based batteries, lithium batteries always need a BMS to perform balancing and safety functions. If electronic components of the BMS fail it can itself become a safety problem for the battery. That's why there is hardware backup for all safety-relevant components in Torqeedo batteries. Incidentally, this is also stipulated in the automotive industry, in aerospace and for medical technology.
5. **Waterproof to IP67** - water in lithium batteries can lead to various problems such as corrosion of the BMS hardware or the creation of electrolytic gas. Lithium batteries on board a boat should therefore be waterproof.

When it comes to high-voltage batteries, only the best is good enough

Torqueedo drives with batteries from BMW i

Cooperation between BMW i and Torqueedo has made the very latest in automotive battery engineering available for boats. The new battery technology introduced in the BMW i3 is now also available for Deep Blue drives from Torqueedo.

The benefits for customers:

- Greater energy density
- Lower costs
- Highest standards of safety.

The latest generation of automotive battery cells

- Very high energy density
- Prismatic cell design allows efficient cooling, a compact form, even temperature distribution within the battery and an extremely rugged structure
- Robust protective aluminium housing with safety vent
- From the automated production process of Samsung SDI, a leading manufacturer of lithium battery cells

Laser-welded cell connections:

over a larger surface and therefore stronger and more powerful than conventional spot-welded cell connections.

Pressure safety disc: The battery is waterproof to IP67. In the unlikely event of excess pressure developing in a cell, the prismatic cells can release the excess pressure through a valve. This is a significant safety advantage over foil-welded or pouch cells. The pressure safety disc allows gases produced in this case to escape and ensures the battery stays waterproof in normal operation.

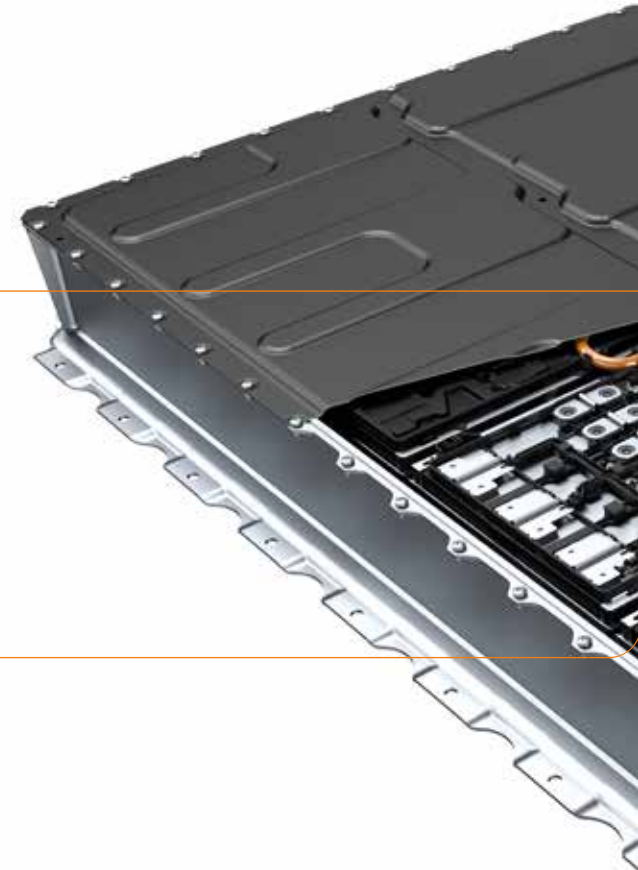

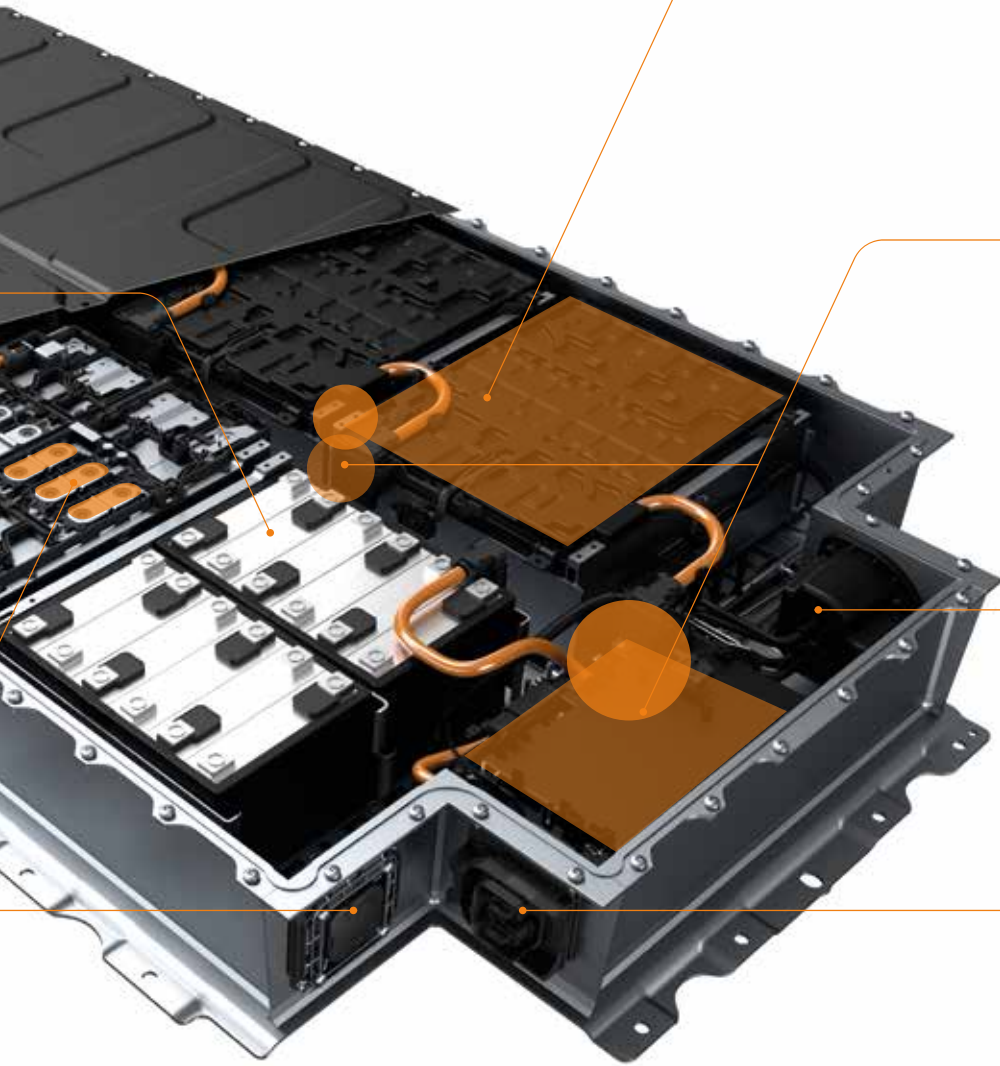

Automated module production

- Prismatic cells have many advantages. However, they must be assembled extremely accurately in a very robust frame for a long service life. (Otherwise charging and discharging would, over time, lead to the cells expanding and collapsing very slightly and cause them to age prematurely.)
- The fully automated module production at BMW in Dingolfing has set the standard in high-precision and extremely robust battery modules
- The very rugged design is ideal for boat applications that place high demands on shock resistance

The fact that the modules are interchangeable will allow upgrading in the future

Battery management system (BMS) at module and battery levels

- State-of-the-art BMS technology
- Developed to ASIL C standards as used in the automotive industry for maximum safety
- Qualification and acceptance testing at a far higher level than is typical in the boating industry

Compressor cooling: Cools the battery to ensure high performance and a long service life even in high ambient and water temperatures - in all climate zones anywhere in the world

Power and data connections from the battery to the Deep Blue system



Electric outboards
and pod drives



22 Ultralight 403

25 Ultralight accessories

26 Travel 503 / 1003 / 1003 C *NEW*

29 Travel accessories

30 Travel bags

32 Cruise outboards

36 Cruise pod drives

42 Electronic throttles & user interface *NEW*

45 Cruise accessories

46 Torq Trac

47 Sunfold 50

48 Power 26-104

51 Power accessories

Ultralight 403

The smallest drive system from Torqeedo. Perfect for kayaks and other extremely light-weight boats. Ideal for kayak fishing with its reliable performance and up to 40 km range thanks to highest efficiency and powerful lithium batteries.

The Ultralight 403 offers all the convenience of a full-feature Torqeedo motor: GPS in real time, solar-rechargeable, waterproof and with a long service life.

- + Capable of travelling at up to 10 km/h and covering up to 40 km
- + Only 8.9 kg total weight including battery
- + On-board computer with real-time display of remaining range, speed, charging status and much more
- + Long-lasting lithium battery without memory effect with shorter charging time and USB connection
- + Compatible with the steering system of all popular kayak models
- + Safe thanks to emergency magnetic kill switch that cuts the motor if you capsize
- + Waterproof to IP67
- + 2-year limited warranty*

*For recreational use, from date of purchase



_ Kayaks
_ very light boats

1 HP
equivalent*

Ultralight 403

*For anglers and adventurers
unwilling to compromise*



* The propulsive power of our Ultralight electric motor is equivalent to comparably rated petrol outboards. Find out more on pages 12/13.

Ultralight 403

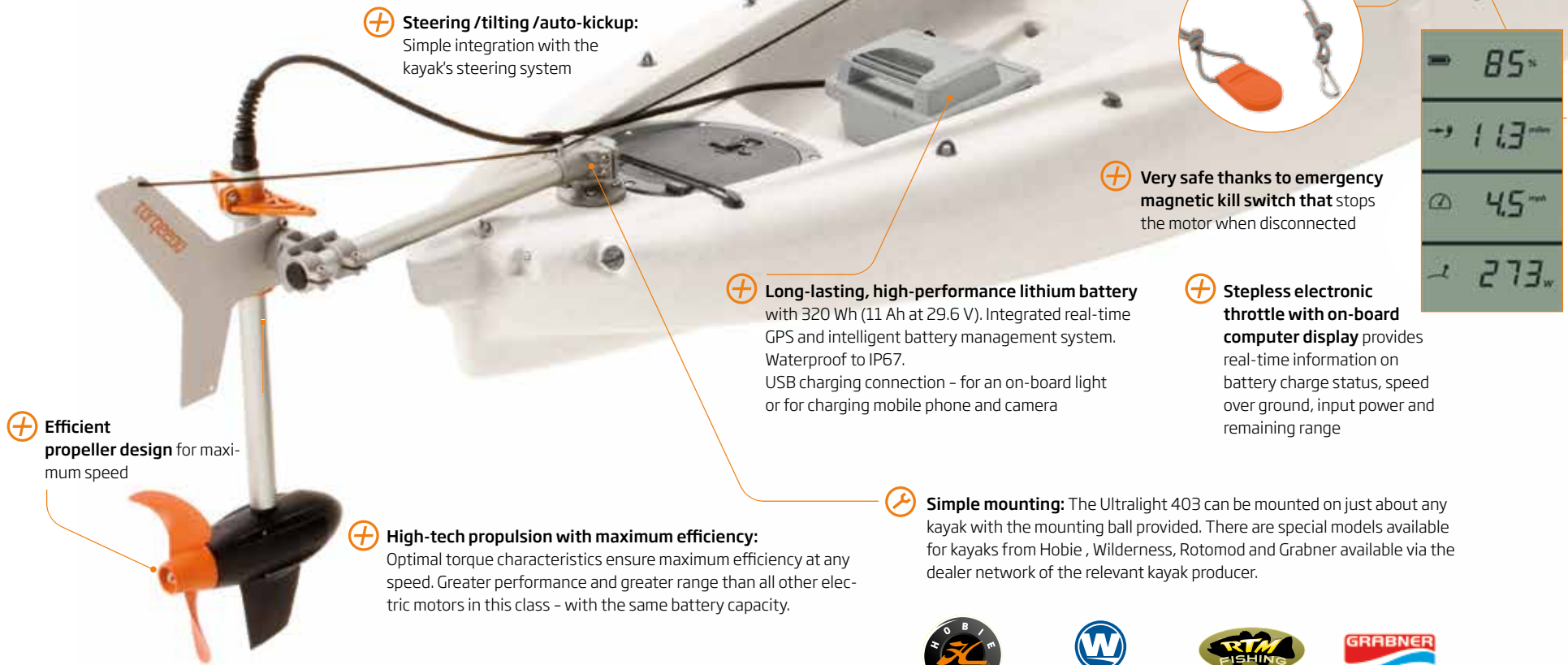

+ **Steering /tilting /auto-kickup:**
Simple integration with the kayak's steering system

+ **Very safe thanks to emergency magnetic kill switch that stops the motor when disconnected**

+ **Long-lasting, high-performance lithium battery** with 320 Wh (11 Ah at 29.6 V). Integrated real-time GPS and intelligent battery management system. Waterproof to IP67. USB charging connection - for an on-board light or for charging mobile phone and camera

+ **Stepless electronic throttle with on-board computer display** provides real-time information on battery charge status, speed over ground, input power and remaining range

+ **Efficient propeller design** for maximum speed

+ **High-tech propulsion with maximum efficiency:** Optimal torque characteristics ensure maximum efficiency at any speed. Greater performance and greater range than all other electric motors in this class - with the same battery capacity.

+ **Simple mounting:** The Ultralight 403 can be mounted on just about any kayak with the mounting ball provided. There are special models available for kayaks from Hobie , Wilderness, Rotomod and Grabner available via the dealer network of the relevant kayak producer.



Performance: speed and range**

Ultralight 403 with integrated lithium battery (29.6 V / 11 Ah)

Fishing kayak (4.1 m / 26.3 kg, Model: Hobie Mirage Revolution)	Speed in km/h	Range in km	Running time in hh:mm
● ● ● Slow	4.2	35.2	08:20
● ● ● Half throttle	6.0	25.0	04:10
● ● ● Full throttle	9.3	7.4	00:48

Ultralight 403 with integrated lithium battery (29.6 V / 11 Ah)

Touring kayak (4.7 m / 23 kg, Model: Prijon Prilite T470)	Speed in km/h	Range in km	Running time in hh:mm
● ● ● Slow	4.2	42.0	10:00
● ● ● Half throttle	6.2	26.0	04:10
● ● ● Full throttle	9.8	7.8	00:48

* The propulsive power of our Ultralight electric motors equivalent to comparably rated petrol outboards. Find out more on pages 12/13.
** Depends on type of boat, load, propeller and conditions. Speed and range indications do not represent a legal guarantee.



 **Simple motor start** at the press of a button

Navigation

TorqTrac

The upgrade for the on-board computer on your smartphone. With convenient navigational functions and GPS data in real time. Find out more on page 46.

Part no. 1924-00



Power supply



Sunfold 50

The plug & play solution for solar-charging the Ultralight 403. This light solar charging panel delivers lots of solar energy and can be easily folded together. Find out more on page 47.

Part no. 1132-00

(suitable for all Ultralight models from 2016)



Spare batteries

Extend your range with a second battery on board. The battery supplied as standard has a capacity of 320 Wh.

Part no. 1416-00

Part no. 1417-00 (915 Wh) *NEW*

You can find further accessories here and from page 71 onwards.

Does the battery need to be fully discharged before I can recharge it?

No, because lithium batteries have no memory effect, i.e. you can fully recharge the battery after each trip regardless of the charge level.

How long does the battery take to charge?

When the battery is completely discharged it takes approx. 5 hours to fully recharge it. A spare battery means that you are mobile again immediately. You can charge your battery with the Sunfold 50 solar charger during your journey.

How long does a lithium battery last?

When used recreationally, the service life of our lithium batteries is virtually independent of the number of times it is charged. Generally speaking, an average capacity loss of 4% a year can be assumed. Ageing will, however, accelerate if the battery is permanently exposed to high temperatures. You can use your battery in high temperatures, but take the battery out of the sun and store it in a cool place when not in use. Your battery must be returned to a Torqeedo Service Centre for service 8 years after manufacture.

What happens if I capsize?

The Ultralight is fitted with a sensor that monitors the position of the motor. If the kayak capsizes or the motor tips up, the drive is automatically switched off. In addition, the emergency magnetic kill switch always must be worn around the wrist or attached to your life jacket. This will stop the motor immediately if required.

Ordering information

Ultralight 403 Ultralight outboard motor (1 HP)*

Part no. 1404-00

Includes:

- _ High-performance lithium battery (320 Wh) with integrated GPS and USB connection
- _ Electronic throttle with on-board computer display
- _ Mounting kit with mounting ball
- _ Charger
- _ Emergency magnetic kill switch

Additional accessories and spares	Part no.
Spare battery Ultralight 403 (320 Wh)	1416-00
Spare battery Ultralight 403 (915 Wh) <i>NEW</i>	1417-00
Spare charger 90 W	1133-00
Motor cable extension 2 m	1920-00
Remote throttle cable extension 1.5 m	1921-00
Remote throttle cable extension 5m	1922-00
Spare propeller v10/p350	1912-00

SERRY
JACHTWERF

Oud-Loosdr. dijk 249 a-d
1231 LX Loosdrecht
Holland
Tel. 035-58 234 04
Fax 035-58 260 80
info@serry.com
www.serry.com

Travel 503 / 1003 / 1003 C **NEW**

The clean alternative to a small petrol outboard: You can go wherever you wish with the Torqeedo Travel - with no exhaust and fuel. With the power and range of a 3 HP petrol motor and all the advantages of an electric drive system from Torqeedo: GPS in real time, USB charging connection and a high-performance battery are only a few of the many extras and convenient features. Now also available in the extra powerful Travel 1003 C version with 73% increased battery capacity.

- + As powerful as a 1.5 or 3 HP petrol outboard
- + Long-lasting high-performance lithium battery
- + Integrated on-board computer with real-time GPS and display of remaining range, speed, charge status and many other functions
- + Very light, weighing 8.9 kg without a battery and only 14.4 kg with one (Travel 1003 S)
- + USB connection for an on-board lamp or for charging a mobile phone or camera
- + Extremely easy handling: tool-free mounting, starts at the press of a button and change of battery within seconds
- + Waterproof to IP67
- + Extra powerful spare battery (option): 73% more energy and greater range for Travel 1003
- + 2-year limited warranty*

*For recreational use, from date of purchase



Travel 1003 C **NEW**

Our most popular Travel 1003 is now available in a version with longer range and run time, courtesy of its lightweight 6 kg, 915 Wh battery. This higher capacity battery combined with the superior overall efficiency of the Travel motors means the Travel 1003 C can run for 18 nm (33 km) at a speed of 3 knots (5.5 km/h).

- _ Tenders
- _ Dinghies
- _ Daysailers
- _ 503: Boats up to 750 kg
- _ 1003/1003 C: Boats up to 1.5 tons

1.5^{HP}
equivalent*

3^{HP}
equivalent*

Travel 503 / 1003 / 1003 C **NEW**

*Clean and convenient - the alternative
to the small petrol outboard*

* The propulsive power of our Travel electric motors is equivalent to comparably rated petrol outboards. Find out more on pages 12/13.

Travel 503 / 1003 / 1003 C

- Clearly audible alarm signal** reports low battery charge
- Very safe thanks to emergency magnetic kill switch** that stops the motor when disconnected
- Stepless speed control** in the tiller, option to connect an electronic throttle
- On-board computer display in the tiller** provides real-time information on battery charge status, speed, remaining range and input power
- Available in two shaft lengths** (62.5 and 75 cm) for every purpose
- Ideal motor cooling in the pylon** ensures maximum performance
- Simple motor start** at the press of a button
- Long-lasting, high-performance lithium battery** with 320 Wh (11 Ah at 29.6 V), 530 Wh (18 Ah at 29.6 V) or 915 Wh (31 Ah at 29.6 V)
- Integrated real-time GPS.** Intelligent battery management system, waterproof to IP67.
- Connection for solar charger** while travelling or when moored up
- Simple mounting:** You can easily attach the Travel to the stern of your boat using the integrated mounting bracket; no special tools are required.
- High-tech drive system** with maximum efficiency: The optimised drive shaft ensures maximum efficiency at any speed – greater performance and greater range than all other electric motors in this class with the same battery capacity.
- Efficient propeller design** for greater propulsive power

Performance: speed and range*

Travel 503 with integrated 320 Wh battery (29.6 V / 11 Ah)

Sailboats up to 750 kg

	Speed in knots (km/h)	Range in nm (km)	Running time in hh:mm
● ● ● Slow	approx. 2.0 (3.7)	approx. 12.8 (23.7)	06:20
● ● ● Half throttle	approx. 3.0 (5.5)	approx. 6.4 (11.9)	02:08
● ● ● Full throttle	approx. 4.0 (7.4)	approx. 2.8 (5.2)	00:42

Travel 1003 with integrated 530 Wh battery (29.6 V / 18 Ah)

Inflatable, dinghy, daysailer up to 1.5 tons

	Speed in knots (km/h)	Range in nm (km)	Running time in hh:mm
● ● ● Slow	approx. 2.0 (3.7)	approx. 20.0 (37.0)	10:30
● ● ● Half throttle	approx. 3.0 (5.5)	approx. 10.5 (19.4)	03:30
● ● ● Full throttle	approx. 5.0 (9.2)	approx. 2.8 (5.2)	00:35

Travel 1003 C with integrated 915 Wh battery (29.6 V / 31 Ah)

Inflatable, dinghy, daysailer up to 1.5 tons

	Speed in knots (km/h)	Range in nm (km)	Running time in hh:mm
● ● ● Slow	approx. 2.0 (3.7)	approx. 35.0 (64.8)	17:30
● ● ● Half throttle	approx. 3.0 (5.5)	approx. 18.0 (33.3)	06:00
● ● ● Full throttle	approx. 5.0 (9.2)	approx. 4.6 (8.4)	00:55

* The propulsive power of our Travel electric motors is equivalent to comparably rated petrol outboards. Find out more on pages 12/13.

** Depends on type of boat, load, propeller and conditions. Speed and range indications do not represent a legal guarantee.

Navigation

TorqTrac

The on-board computer on your smartphone offers convenient navigational functions in real time. Find out more on page 46.

Part no. 1924-00



Power supply

Sunfold 50

This lightweight solar charger panel converts solar energy into power and can be easily folded together. Suitable for all Travel models from 2015. Find out more on page 47.

Part no. 1132-00



Electronic throttle

Instead of using the tiller, you can control your Travel motor with the throttle located at 1.5 or 5 metres away. It comes with on-board computer display, stepless speed control and two different lengths of data cable.

Part no. 1918-00



Spare battery

Extend your range with a second battery on board. Weight: only 6 kg.

Part no. 1148-00 (915 Wh)

Part no. 1147-00 (530 Wh)

Protection & transport

Protective cover

Protect the motor cover from intensive sunlight and dirt.

Part no. 1931-00



Travel bags

Transport your Travel motor and battery conveniently in stylish carry bags. Convenient and protective.

Part no. 1925-00 (Travel bag, 2-piece)

Part no. 1926-00 (Travel battery bag)

You can find further accessories here and from page 71 onwards.

Which Travel for which boat?

All three models are suitable for inflatables and other small boats. For sailboats up to 750 kg we recommend the Travel 503. The Travel 1003 easily propels up to 1.5 tons. Both models provide similar performance on the same boat at the same speed. However, the Travel 1003 has a higher maximum power and offers over 60% more battery capacity, providing longer range.

Does the battery need to be fully discharged before I can recharge it?

No, because lithium batteries have no memory effect, i.e. you can fully recharge the battery after each trip regardless of the charge level.

How long does the battery take to charge?

That depends on how you charge the battery. Using the charger supplied, it takes about five hours for the Travel 503 and about seven hours for the Travel 1003 until the battery is fully recharged. You can also recharge the battery direct

from the 12 V on-board power system. (Accessory required). A full charge with the Sunfold 50 (accessory), which can also charge while travelling takes around 10 hours.

How long does a lithium battery last?

When used recreationally, the service life of our lithium batteries is virtually independent of the number of times it is charged. Generally speaking, an average capacity loss of 4% a year can be assumed. Ageing will, however, accelerate if the battery is permanently exposed to high temperatures. You can use your battery in high temperatures, but take it out of the sun and preferably store it in a cool place when not in use for some time. Your battery must be returned to a Torqeedo Service Centre for service 8 years after manufacture.

Will high temperatures damage the battery?

No, because we've integrated a temperature

protection mode. Motor power is automatically reduced before the battery gets too hot until the temperature returns to a level where there is no risk of damage to the battery. This function is represented in the display with a thermometer.

What safety precautions need to be observed?

The emergency magnetic kill switch must always be worn around the wrist or attached to your life jacket. This will stop the motor immediately if required. Falling out of the boat will also result in the motor being stopped. Even brief complete immersion of the components (for example when capsizing) will result in no damage to the outboard as all components are designed to be waterproof to IP67.

You can find more information about this product at: www.torqeedo.com/travel

Ordering information

Travel 503/1003 (C)
High-tech outboard
(Travel 503: 1.5 HP,
Travel 1003 (C): 3 HP)*

Travel 503 S	Part no. 1140-00
Travel 503 L	Part no. 1141-00
Travel 1003 S	Part no. 1142-00
Travel 1003 L	Part no. 1143-00
Travel 1003 CS NEW	Part no. 1149-00
Travel 1003 CL NEW	Part no. 1150-00

Includes:

- High-performance lithium battery (Travel 503: 320 Wh / Travel 1003: 530 Wh / Travel 1003 C: 915 Wh)) with integrated GPS and USB connection
- On-board computer display in the tiller
- Emergency magnetic kill switch
- Charger

Additional accessories and spares	Part no.
Spare battery 915 Wh	1148-00
Spare battery 530 Wh	1147-00
Spare charger 90 W	1133-00
Motor cable extension	1920-00
Remote throttle cable extension 1.5 m	1921-00
Remote throttle cable extension 5m	1922-00
12/24 V charger cable	1128-00
Spare propeller v9/p790 (2-blade, for Travel 503 / 1003)	1917-00
Spare propeller v8/p350 (for Travel 503 until production end 2014)	1901-00
Long tiller arm (60 cm)	1919-00

Travel Bags

*_ For Travel 503/1003/1003 C
models and Travel spare battery*



Securely packed and stowed away

Our elegantly designed travel bags are practical for carrying and stowing your Travel motor and spare battery - and they look good, too.



Travel battery bag

Additional carry bag for an additional battery. With adjustable, removable shoulder strap and zip fasteners in orange.

Part no. 1926-00



Travel bags

Weather-resistant carry bags in the Torqeedo look. In silver-grey with orange details. Black lining with padding protects your Travel motor - including tiller, battery and accessories. With functional details and practical carrying handles.

Part no. 1925-00 (2-piece)

Cruise outboards

Our Cruise series stands for smooth, powerful performance. They are ideally equipped to meet the challenges of daily use and they feature all the advantages of a Torqeedo high-tech drive system.

The **Cruise 10.0 R** is the flagship of the Cruise series. Fast and powerful, the motor was designed from the ground up to feature the easy handling of a 48 volt system while delivering the thrust of a 20 horsepower combustion outboard.

- + 10 kW continuous input power - 12 kW peak power
- + More range and power than any other electric 48 volt outboard
- + Minimum weight with maximum performance
- + On-board computer with GPS
- + Extra robust design - waterproof to IP67
- + High level of corrosion protection, even in sea water
- + Operates with lithium or AGM/lead-gel batteries
- + 2-year limited warranty**

**For recreational use, from date of purchase



- _ Motorboats and dinghies
- _ Sailboats up to 10 tons
- _ Commercial users

5^{HP}
equivalent*

8^{HP}
equivalent*

20^{HP}
equivalent*

Cruise outboards

Power, endurance and convenience without compromise for leisure and commercial use



* The propulsive power of our Cruise electric drives is equivalent to comparably rated petrol outboards. Find out more on pages 12/13.

Cruise outboards

High-tech drives with maximum efficiency

The optimal torque characteristics of Torqeedo drive systems ensure maximum efficiency at any speed – higher performance and greater range than all other electric motors in this class – with the same battery capacity. Equipped with all of the convenience of a genuine Torqeedo high-tech motor.

- + All models have a GPS on-board computer and display** in the tiller or electronic throttle with real-time display of speed and input power – and the exact battery status and remaining range when used in combination with the Power 26-104 lithium battery.
- + Housing and all plug connections waterproof to IP67**
- + Extra robust design**, with lubricant-free polymer plain bearing. Protect against damage from debris – wear-resistant and maintenance-free
- + Stable pylon made from highest-grade seawater-proof aluminium** and with an extra-reinforced fin, suitable for the toughest conditions
- + Simple motor start** at the press of a button

Cruise 2.0 R/T

Also available with tiller



Cruise 4.0 R/T

Also available with electronic throttle

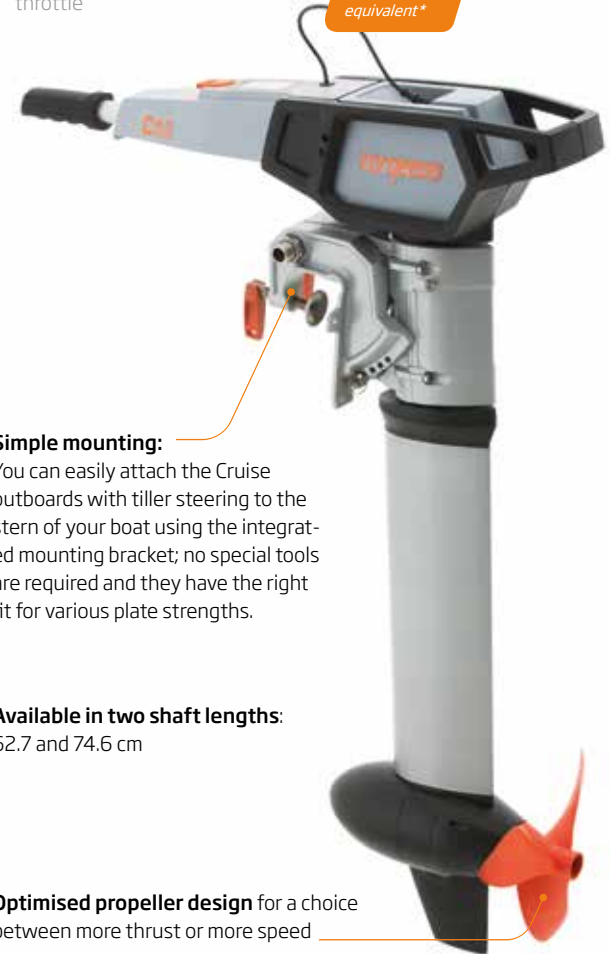

- + Simple mounting:** You can easily attach the Cruise outboards with tiller steering to the stern of your boat using the integrated mounting bracket; no special tools are required and they have the right fit for various plate strengths.

- + Available in two shaft lengths:** 62.7 and 74.6 cm

- + Optimised propeller design** for a choice between more thrust or more speed

Performance: speed and range*

Cruise 2.0 with 2 lead batteries (2 x 12 V / 200 Ah, battery weight approx. 120 kg)

Dinghies and yachts up to 3 tons	Speed in knots (km/h)	Range in nm (km)	Running time in hh:mm
● ● ● Slow	approx. 2.7 (5.0)	approx. 27 (50)	10:00
● ● ● Full throttle	approx. 6.0 (11.1)	approx. 12 (22)	02:00

Cruise 4.0 with 2 x Power 26-104 (26 V / 104 Ah, battery weight 48 kg)

Motorboats and sailboats up to 4 tons	Speed in knots (km/h)	Range in nm (km)	Running time in hh:mm
● ● ● Slow	approx. 2.7 (5.0)	approx. 29 (54)	10:45
● ● ● Full throttle	approx. 7.0 (13.0)***	approx. 8 (15)	01:10

* The propulsive power of our Cruise electric motors is equivalent to comparably rated petrol outboards. Find out more on pages 12/13.

** Depends on type of boat, load, propeller and conditions. Speed and range indications do not represent a legal guarantee.

*** Planing with Cruise: light boats can reach planing speeds up to 15 knots (28 km/h).



Cruise 10.0 R

20^{HP}
equivalent*



The flagship of the Cruise series: The impressive Cruise 10.0 R offers an impressive set of technical data. The outboard provides a range of up to 30 km at a speed of 30 km/h.

Operating voltage of 48 V ensures easy handling and straightforward maintenance. This makes the Cruise 10.0 R the ideal motor for tender RIBs, accompanying boats for training and for use on protected waters.

- + 12 kW peak output and 10 kW continuous output for powerful propulsion
- + Electric tilting device for ease of operation
- + Intelligent on-board computer
- + Easy handling thanks to low-voltage level of 48 V
- + Corrosion-protected, sea water-capable and completely waterproof to IP67
- + Extremely rugged design including for commercial use in fresh water or sea water
- + Three shaft lengths
- + Various propeller and throttle options
- + 2-year limited warranty*

*For recreational use, from date of purchase

Cruise 10.0 with 4 × Power 26-104 (26V / 104Ah, battery weight 96 kg)

Motorboats and sailboats up to 10 tons	Speed in knots (km/h)	Range in nm (km)	Running time in hh:mm
● ● ● Slow	4.2 (7.8)	35.2 (65)	08:20
● ● ● Full throttle	17.2 (31.9)	14.0 (26)	00:48



Cruise pod drives

With Torqeedo's Cruise pod drives, electric motor systems are a true alternative to inboard diesels.

The motor unit, proven successful in thousands of outboards, is just one component of an integrated system that offers superior performance and convenience. It is complemented by Torqeedo's own lithium batteries, developed to work flawlessly with our motors, and by our new electronic throttle designed specifically for sailboats. It also features a state-of-the-art user interface.

The system can be charged from shore power, from solar and from generator. It also creates its own energy acting as a hydro-generator while sailing.

Torqeedo's Cruise pod systems are available for sailboats from 25 to 40 ft.

- + Space-saving, powerful, lightweight
- + Plenty of range due to highest efficiency
- + On-board computer with GPS
- + Can be used as hydro-generator to create power
- + High level of corrosion protection, salt water-capable
- + 2-year limited warranty**

**Recreational use, from date of purchase



- _ Sailboats up to 10 tons
- _ Commercial users
- _ Motor boats

5^{HP}

equivalent*

8^{HP}

equivalent*

20^{HP}

equivalent*

Cruise pod drives

*Lightweight, high-performance,
power-generating and
space-saving: the coming-of-age
of electric motors for sailboats*

* The propulsive power of our Cruise pod electric motors is equivalent to comparably-rated petrol outboards. Find out more on pages 12/13.

Cruise Pod Drives



Saildrive adapter kit

Refitting a lightweight and space-saving electric pod drive into a saildrive mount is easy. Ask us for a saildrive adapter kit.

A compelling system, created from first class components

Torqueedo offers the first fully integrated 48 Volt electric marine propulsion system from industrial production. The heart of the system is the Cruise FP motor, available in three power levels.

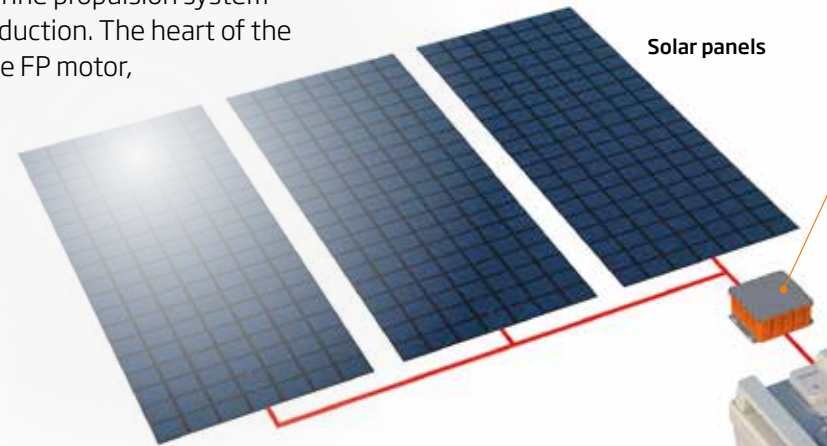

Solar panels

High-performance lithium batteries, designed specifically to work with Torqueedo propulsion systems. 5-stage safety concept, see battery details starting on p. 48

Motor: lightweight, efficient, reliable

- Superior performance
- Proven successful in thousands of applications
- Extremely lightweight (8 HP equivalent weighs a mere 9 kg)
- Available in power equivalent to 5 HP, 8 HP, 20 HP combustion engine outboards

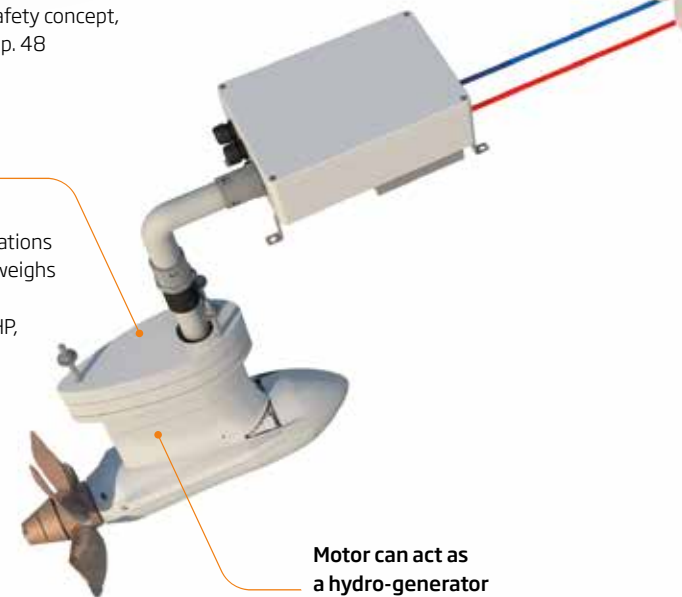

Motor can act as a hydro-generator

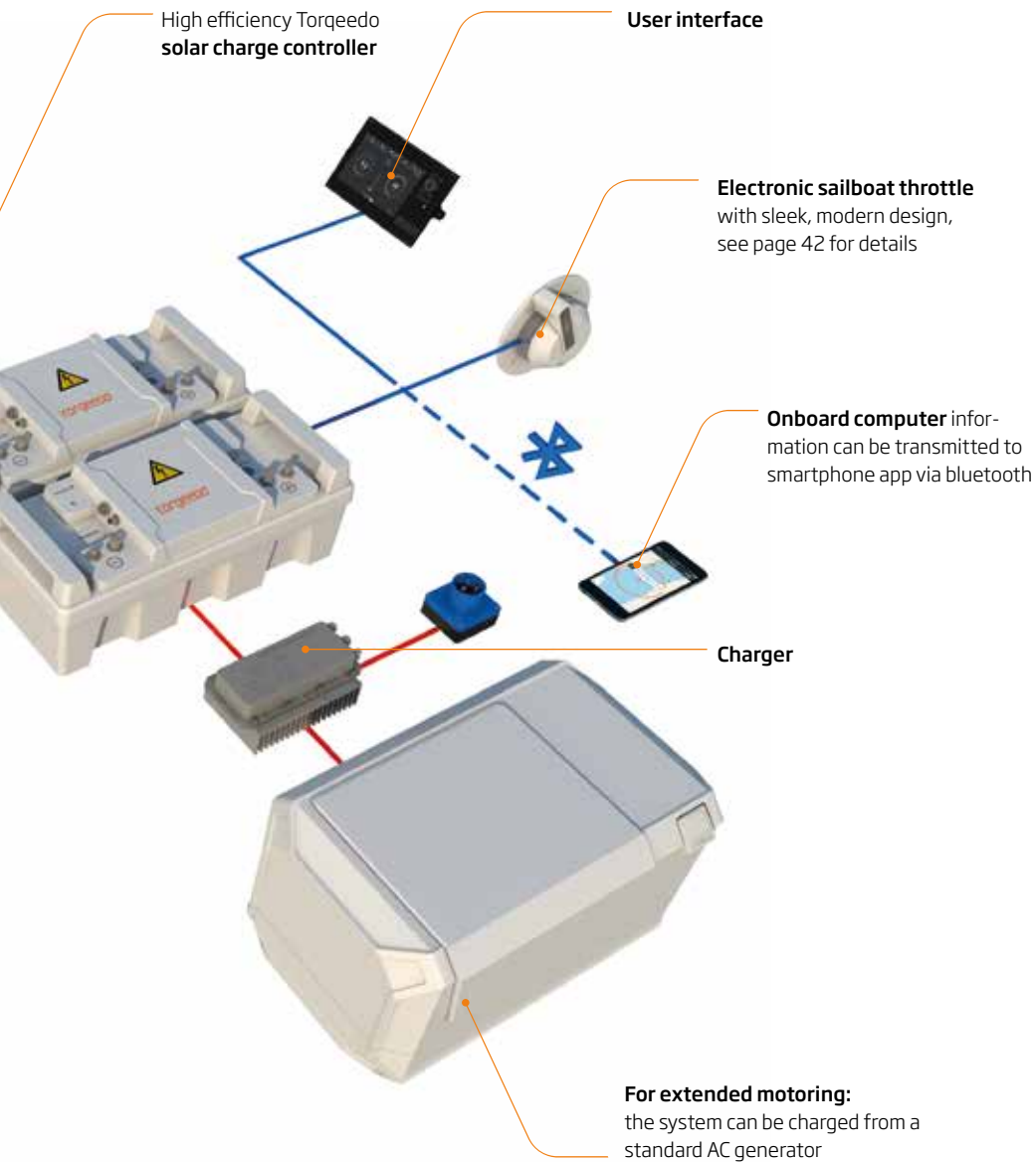

How does a Pod motor impact flow resistance while sailing?

What is the impact of a pod motor on the performance of a sailboat? Since efficiency is an important principle at Torqeedo, even while a motor is not in use, we have calculated the flow resistance of a 30' Dehler yacht with and without a pod motor. The results: The impact of a Torqeedo Cruise 2.0 or 4.0 Pod motor on a sailboat's performance is minimal: a decrease of less than 0.04 knots speed - compared to having no motor at all.

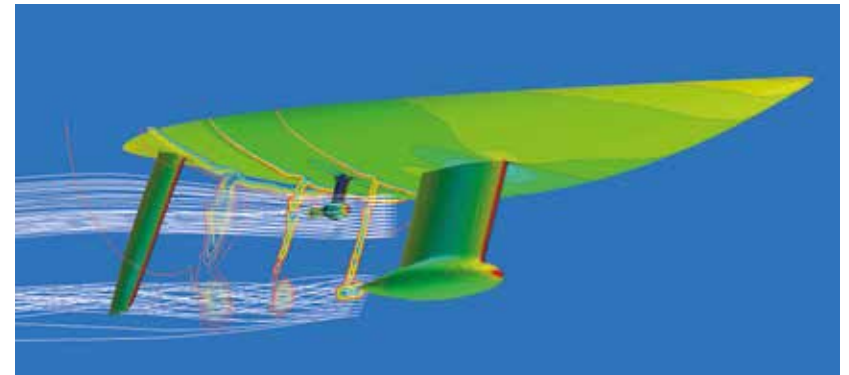
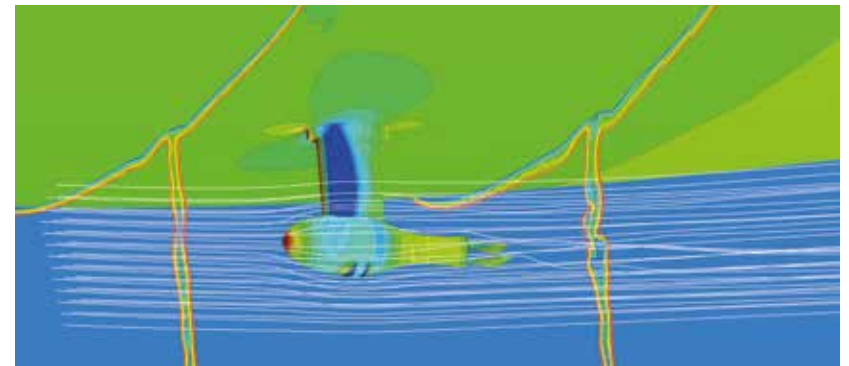

Illustration of flow with listing and windward drift from ahead



Water flow around a Torqeedo pod motor

Cruise Pod Drives



Hanse E-Motion Rudder Drive in cooperation with Torqeedo and Jefa

Cruise FP models are light and small. So why not integrate them in the rudder? This saves a hole through the hull, eliminates the need for a saildrive and a stern thruster and provides fantastic maneuverability.

Taking advantage of all the benefits from electric pod motors and combining them with the elegance of a rudder integration, Hanse is making a splash with their electric Hanse 315. We consider this the first time a leading large-scale sailboat manufacturer has offered a true electric alternative to the diesel inboard. The benefits:

- + 100 kg lighter
- + Quieter
- + Lower maintenance
- + No diesel smell and diesel in the bilge
- + Better maneuverability
- + Less drag and better performance under sail

Pod integrated in rudder



Hanse 315	Speed in knots (km/h)	Range in nm (km)	
		with 2 Batteries	with 4 Batteries
● ● ● Slow	3.0 (5.6)	33.2 (61.4)	66.2 (122.9)
● ● ● Half throttle	5.0 (9.2)	13.2 (24.4)	26.4 (48.8)
● ● ● Full throttle	6.0 (11.1)	7.5 (13.9)	15.0 (27.8)

Cruise 2.0 FP

5^{HP}
equivalent*



+ **Stable pylon** made from highest-grade seawater-proof aluminium

+ **Extra robust design** protects against damage from debris - wear-resistant and maintenance-free

Cruise 4.0 FP

8^{HP}
equivalent*



Folding propellers available as accessories for all models

Cruise 10.0 FP

20^{HP}
equivalent*



+ **Maximum efficiency** for greater performance and range

+ All models with **GPS on-board computer and display**: real-time display of speed and input power - and also the exact battery status and remaining range when used in combination with the Power 26-104 lithium battery

+ **Connection to TorqTrac**: the premium on-board computer on your smartphone



Performance: speed and range**

Cruise 2.0 FP with 2 lead batteries
(2 × 12 V / 200 Ah, battery weight approx. 120 kg)
Sailboats up to 3 tons

	Speed in knots (km/h)	Range in nm (km)	Running time in hh:mm
● ● ● Slow	approx. 2.7 (5.0)	approx. 24.3 (45.0)	09:00
● ● ● Full throttle	approx. 6.0 (11.1)	approx. 10.5 (19.5)	01:45

Cruise 4.0 FP with 2 × Power 26-104
(26 V / 104 Ah, battery weight 48 kg)
Sailboats up to 4 tons

	Speed in knots (km/h)	Range in nm (km)	Running time in hh:mm
● ● ● Slow	approx. 2.7 (5.0)	approx. 26.1 (48.3)	09:40
● ● ● Full throttle	approx. 6.0 (11.0)	approx. 7.5 (13.9)	01:15

Cruise 10.0 FP with 4 × Power 26-104
(26 V / 104 Ah, battery weight 96 kg)
Motorboats and sailboats up to 10 tons

	Speed in knots (km/h)	Range in nm (km)	Running time in hh:mm
● ● ● Slow	approx. 3.8 (7.0)	approx. 24.6 (45.5)	06:30
● ● ● Full throttle	approx. 17.3 (32.0)	approx. 15.9 (29.5)	00:55

* The propulsive power of our Cruise electric pod motors is equivalent to comparably rated petrol outboards. Find out more on pages 12/13.

** Depends on type of boat, load, propeller and conditions. Speed and range indications do not represent a legal guarantee.

Electronic throttles & user interface **NEW**

We've come to expect an intuitive way to operate our technical devices. We expect detailed information, nicely displayed and clearly arranged. We expect that objects we use provide not only function but beauty.

This is what spurred us to create the new Torqueedo throttle family and the improved user interface for Deep Blue and Cruise motor systems.

*The right control
for every
application*

Side-mount Sail

Electronic throttle designed specifically for sailboats. Sleek design, unobtrusive lever. No gap between throttle lever and cockpit side, so no lines can entangle. Neutral-lock for safe operation.



— Cruise FP
— Deep Blue Saildrive

Side-mount Motor

Classic electronic throttle for motor boats with power trim and tilt. Mechanical zero-point release under the handle, can be mounted on either side of the boat. Neutral-lock for safe operation.



— Cruise R
— Deep Blue

Top-mount Single

Drive-by-wire throttle for surface mounting with ergonomically optimised, extra-wide handle surface and broad hand-rest, integrated power trim and tilt function and integrated display in the base.



— *Cruise R*
— *Deep Blue models*

Top-mount Twin

Dual throttle for twin motors for surface mounting with ergonomically optimised handle surface, integrated power trim and tilt function and integrated display in the base.



— *Cruise R as twin installation*
— *Deep Blue as twin installation*



New user interface

Torqeedo has always provided meaningful information systems for even the smallest motors. The new 2017 user interface for Deep Blue and Cruise motors marries informative and functional data with high resolution marine displays and clean aesthetics.

— *Cruise*
— *Deep Blue*

Cruise accessories

All Cruise models can be run with modern lithium batteries, saving over 70% of battery weight in electric boat drive systems. AGM or lead-gel batteries are an alternative to lower the initial cost if saving weight and volume are not important. For best performance, choose Power 26-104.



Power 26-104

High-performance lithium battery from our own in-house development specially designed for powering the Cruise. Can also be used for a 24 V on-board power system. The Power 26-104 communicates directly with the Cruise motor - in real time. The on-board computer continuously shows dependable information on battery status and the remaining range. Furthermore, the Power 26-104 offers all the benefits of a lithium battery combined with extraordinary safety.

- _ Low weight with high performance - up to 70% lighter than AGM or lead-gel batteries
- _ Outstanding performance even in cold weather
- _ Long service life without memory effect
- _ Intelligent battery management system (BMS)
- _ Multi-level protection mechanisms for maximum safety
- _ Excellent high-current capacity for high-performance applications
- _ High charge stability over time

Find out more on the Power battery starting on page 48.

Part no. 2103-00

Battery options	Cruise 2.0 R/T/FP		Cruise 4.0 R/T/FP		Cruise 10.0 R/FP	
	Power 26-104 (lithium)	Others (AGM / gel)	Power 26-104 (lithium)	Others (AGM / gel)	Power 26-104 (lithium)	Others (AGM / gel)
Required battery voltage	24 V	24 V	48 V	48 V	48 V	48 V
Number of batteries	1	2	2	4	4	8
Nominal charge (20 hour discharge power)	104	150	104	150	208	300
Battery bank capacity in kWh	2.7	3.6	5.4	7.2	10.8	14.4
Capacity not available in typical electric boating application (5 hour discharge rate)	n/a	20%	n/a	20%	n/a	20%
Capacity not available if deep discharge damage is to be avoided	n/a	20%	n/a	20%	n/a	20%
Usable energy for electric boating in kWh	2.7	2.2	5.4	4.3	10.8	8.6
Battery bank weight (in kg)	24	88	48	176	96	352



AGM or lead-gel batteries on the Cruise

AGM or lead-gel batteries are recommended for electric boat systems where initial cost is a major concern and weight and volume are of secondary importance. When equipping an electric drive system with AGM or lead-gel batteries, care should be taken to choose models with demonstrably high discharge capacities. Batteries without this property, like most starter batteries, cannot cope with the massive loads drawn by boat drive systems over the long term and can very quickly reach the end of their useful life.

Navigation



TorqTrac

The upgrade for the on-board computer on your Bluetooth smartphone. With convenient navigational functions in real time. Find out more on page 46.

Part no. 1924-00

Propeller



High-speed propeller v30/p4000

This propeller was specifically calculated for high speeds.

Part no. 1923-00

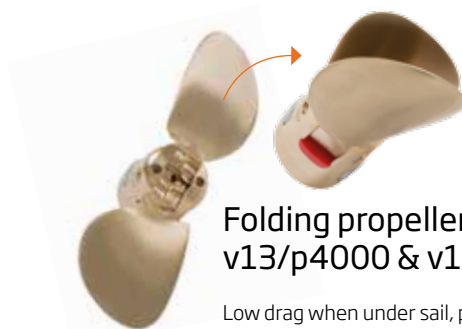

Folding propeller v13/p4000 & v15/p10k

Low drag when under sail, powerful propulsion while motoring.

Part no. 1932-00 (Cruise 2.0/4.0 FP)

Part no. 1945-00 (Cruise 10.0 FP)

You can find further accessories here and from page 71 onwards.

What type of battery supply does the Cruise need?

Cruise motors can be operated with modern lithium batteries or with conventional AGM or lead-gel cell batteries. The Power 26-104, which was developed for use with the Cruise, offers a number of advantages. AGM or lead-gel batteries are less expensive to buy but provide only limited functionality for the Cruise and a shorter service life.

Is the on-board computer compatible with lead batteries?

Yes, but with the limitation that lead batteries do not have a battery management system supplying important information. The charge status display and the remaining range

are based on derived estimates of battery information that is entered when the battery is first installed.

What advantages does the Power 26-104 lithium battery offer for the Cruise?

A lithium battery provides significantly greater performance with lower weight than conventional lead batteries. You benefit in terms of range and power thanks to the lower weight of the boat. The integrated battery electronics of the Power 26-104 are designed to communicate with the on-board computer of the Cruise, providing values such as remaining range and capacity in real time.

What requirements must my boat meet for twin motors - the Twin Cruise?

A Twin Cruise motor system consists of two Cruise models with remote throttle control and the Twin Cruise extension set, which contains a dual throttle and tie bar. The tie bar is used to connect the two Cruise outboards to the same steering mechanism. The standard Twin Cruise mounting assumes a transom width of at least 76 cm.

You can find more information about this product at: www.torqueedo.com/cruise

Ordering information

Cruise 2.0 / 4.0 / 10.0 High-tech outboards

Part no.	TS	TL	RS	RL	RXL
Cruise 2.0	1234-00	1235-00	1230-00	1231-00	-
Cruise 4.0	1236-00	1237-00	1232-00	1233-00	-
Cruise 10.0	-	-	1240-00	1241-00	1242-00

Includes:

- Integrated on-board computer with GPS and display
- Fuse and main switch
- Emergency magnetic kill switch
- Cable set (3m)
- Battery cable bridge for lead batteries
- Tiller steering (T models) or throttle (R models)
- Connection with remote steering system (R models)

Cruise 2.0 / 4.0 / 10.0 FP High-tech pod drives

Cruise 2.0 FP
Cruise 4.0 FP
Cruise 10.0 FP

Part no. 1250-00
Part no. 1251-00
Part no. 1252-00

Includes:

- Integrated on-board computer with GPS and display
- Fuse and main switch
- Emergency magnetic kill switch
- Cable set (3m)
- Battery cable bridge for lead batteries
- Throttle

Additional accessories and spares

Part no.

Spare propeller v19/p4000 (fast, efficient, weedless)	1916-00
Folding propeller v13/p4000 (Cruise 2.0/4.0 FP)	1932-00
Folding propeller v15/p10k (Cruise 10.0 FP)	1945-00
Long tiller arm, 60 cm	1919-00
Twin Cruise extension set	1217-00
Motor cable extension (Cruise 2.0/4.0)	1204-00
Remote throttle cable extension 1.5 m	1921-00
Remote throttle cable extension 5m	1922-00

TorqTrac

— **Ultralight 403**
— **Travel 503/1003/1003 C**
— **all Cruise models**

The upgrade for the on-board computer on your Bluetooth smartphone. With convenient navigational functions in real time.

- + Extensive navigation functions
- + Extremely easy to use
- + Wireless Bluetooth communication with your mobile phone
- + 2-year limited warranty*

*For recreational use, from date of purchase

Part no. 1924-00

Bluetooth® transmitter module for a wireless connection between the on-board computer and a smartphone (system requirement: Bluetooth® 4.0 LE low energy). The associated app for Apple and Android can be downloaded free from your vendor's App Store. Microsoft apps are currently not supported.

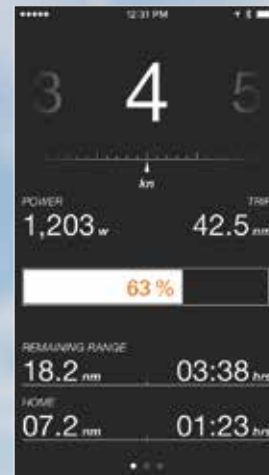
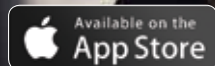

Clear: All the values are easy to read on your smartphone display, even at night.

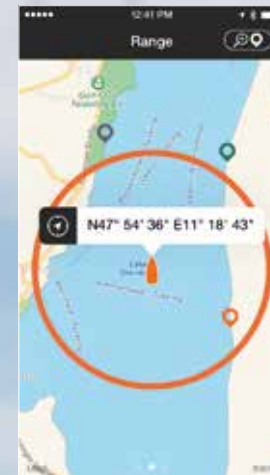

Precise: You always know your exact position and the remaining range thanks to GPS positioning data updated in real time.

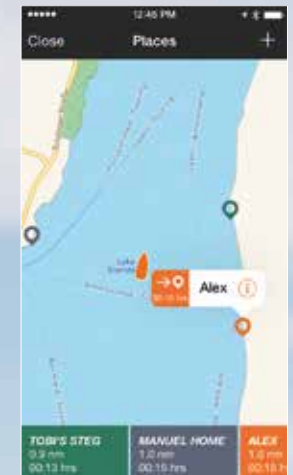

Convenient: Use waypoints to estimate your time of arrival, zoom into the map and save your favourite places.

Sunfold 50 *Simply fill up with sun*

- + Fill up for free
- + Environmentally friendly solar energy
- + Freedom from charging stations and marinas
- + Simple handling and transport
- + 2-year limited warranty*

*For recreational use, from date of purchase

_ Ultralight 403
_ Travel 503/1003/1003 C

For all Travel models as well as for the Ultralight 403 battery from 2016

The Sunfold 50 solar panel delivers plentiful solar energy thanks to its high-performance solar cells made from monocrystalline silicon, enabling Travel and Ultralight batteries to recharge, even while underway. When folded for storage, the Sunfold measures just 60 x 38 cm

Part no. 1132-00

For batteries with part numbers 1146-00, 1147-00, 1148-00, 1416-00 and 1417-00. With protective cover for transport and storage.

Rated output	50 W under standard test conditions
Cells	High-performance cells made from monocrystalline silicon
Cell efficiency	17.8%
Dimensions	37.5 × 60.5 cm folded 37.5 × 121 cm opened (0.45 m ²)
Weight	2.4 kg
Waterproof	IP65, connection to battery waterproof, charging on the water possible without the risk of electrolytic corrosion
Can be used with other 12 V devices	

* New-generation Ultralight batteries from 2016

Power 26-104

Installed and activated in a few simple steps. The high-performance plug and play lithium battery for your Cruise motor or on-board power supply.

Choosing the Power 26-104 means choosing a state-of-the-art, professionally developed safety system, unrivaled in the marketplace.



- + 5-stage safety system provides peace of mind
- + Up to 70% lighter than AGM or gel batteries
- + Proven battery management system for a long service life
- + Minimal self-discharge
- + Simple plug & play handling
- + Automatic hibernation mode
- + Waterproof to IP67
- + 2-year limited warranty*

*For recreational use, from date of purchase



Power 26-104

*24 V power supply -
for the Cruise and for other
electric devices on board*

Power 26-104

The ultimate solution for powering your electric boat and other 24 V loads. Add a converter to provide different voltage levels.



Integrated information system identifies the battery and communicates with the Cruise on-board computer

Housing and all plug connections **waterproof to IP67**

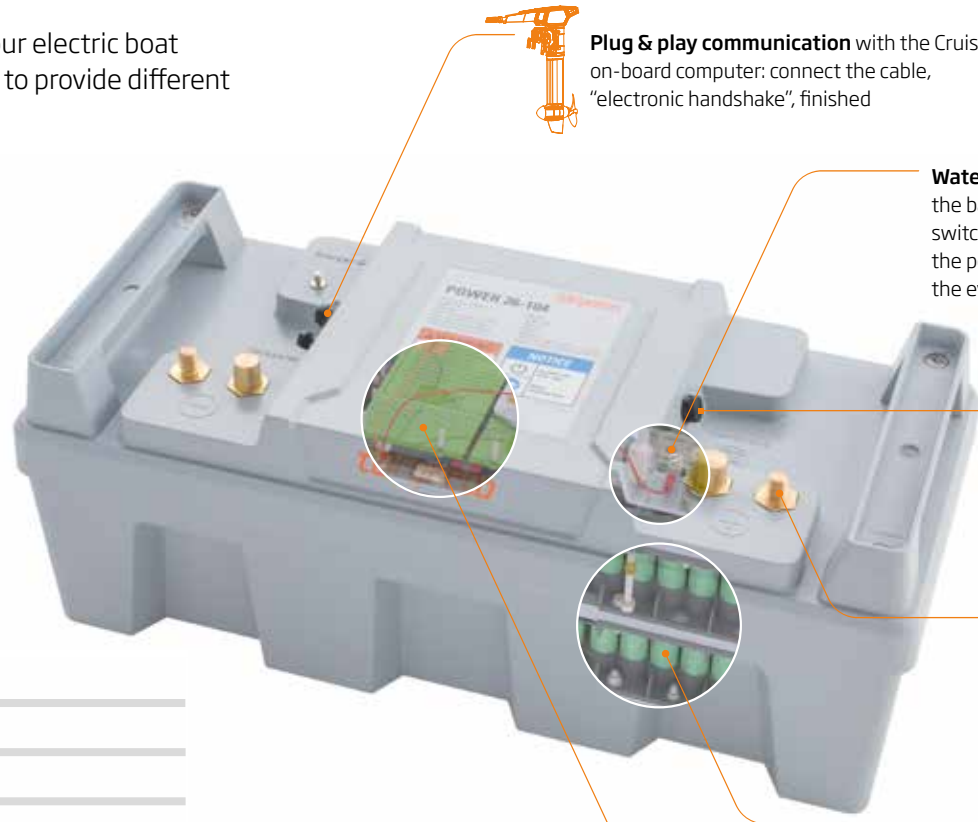

Plug & play communication with the Cruise on-board computer: connect the cable, "electronic handshake", finished

Water-sensor protection recognises when the battery is submerged and automatically switches the voltage off at the poles. Prevents the potential formation of electrolytic gas in the event that water gets into the boat

Waterproof venting balances differences in temperature and pressure without compromising waterproof qualities

Isolatable poles ensure protection for safe transport and installation, and also guard against unintentional discharging when stored for long periods

Highest quality lithium battery cells from the fully automated production of the most prestigious Japanese and Korean manufacturers

A sophisticated battery management system (BMS) contributes additional protective and balancing functions for long battery life

Safety cells with multiple protection:
The individual battery cells consist of welded steel cylinders equipped with several hardware safety mechanisms

Technical data

Capacity	2,685 Wh
Nominal voltage	25.9 V
Nominal charge	104 Ah
Weight	24.3 kg
Energy density (weight)	110 Wh/kg
Maximum discharge rate	180 A (4,500 W at nominal voltage)
Dimensions	577.5 x 218.5 x 253.5 mm
Battery chemistry	Li NMC
Cycle lifetime	800 cycles at 100% depth of discharge at 25 °C results in approx. 25% capacity loss
Annual capacity loss	4 %
Max. connections	2S8P or 1S16P
Price-performance	EUR 0.93 /Wh

Maximum performance and maximum safety

Accessories



Charger 350 W

You can recharge the Power 26-104 from 0 to 100% in a maximum of 11 hours. Charging current 10 A, waterproof to IP65.

Part no. 2206-20

Fast charger 1,700 W

Recharges the Power 26-104 from 0 to 100% in approx. 2 hours (maximum 60 A / 1,700 W), or with 110 V in less than 4 hours (maximum 26 A / 750 W). Waterproof to IP65.

Part no. 2210-00



Can I use the Power 26-104 to power other electric devices?

The Power 26-104 provides all the energy needed to power your 24V on-board equipment. The output may be converted to other voltage levels, if required.

What temperatures must be taken into account during operation, when charging and for storage?

Operating temperatures can be between -15 °C and 60 °C, and for charging between 0 °C and +45 °C. Storage temperature can be between -30 °C and +55 °C, with room temperature having a positive effect on life expectancy. The integrated battery management system protects the batteries against low temperatures and overheating during operation and charging. The BMS steps in to prevent the risk of damage through incorrect temperatures.

You will find more information about this product at: www.torqueedo.com/ultralight



On/off switch

Easily activate or deactivate the Power 26-104 when using it for an on-board power supply. With LED indicator light. Waterproof to IP65.

Part no. 2304-00



Solar charge controller 232 W

Safely charge your Power 26-104 with 3rd-party solar modules. The integrated electronics ensure an efficient, optimised energy yield. Output power up to 232 W (8 A at 29.05 V).

Part no. 2207-00

You can find further accessories here and from page 71 onwards.

I rarely use my battery and store it for long periods. Will this damage a Power 26-104?

The latest Power 26-104 models have an automatic deactivation mode. The battery's electronics will switch off 48 hours after the last use and the battery will go into hibernation mode. The battery can remain in this mode for up to a year provided it is charged to at least 30% of capacity. Even so, a check should be made on the battery's charge status every two months when stored for long periods. The battery should be quickly recharged after every complete discharge. Avoid discharging a battery fully and then storing it for a long time (without charging it) since that damages any type of battery.

Why does the Power 26-104 have a discharge limit?

One of the advantages of lithium batteries is that they can deliver very high currents. The flipside of this is that lithium batteries can do substantial damage if a short circuit occurs and high short circuit currents are not prevented. In Power 26-104, this important safety feature is integrated into the battery management system. If higher power limits are required, batteries can be connected in parallel, this way the maximum power limit can be multiplied.

What is the warranty on the Power 26-104?

As with all our products, we give a 2-year warranty from the date of purchase for recreational use.

Ordering information

Power 26-104
High-performance lithium battery with 2,685 Wh (25.9 V / 104 Ah)

Part no. 2103-00

Includes:

- _ Data cable for connection to a Torqueedo Cruise drive system



Indication of battery capacity: All Torqueedo battery capacity ratings refer to usable energy. We rate only the portion of the battery's capacity that you can really use. (Other battery manufacturers generally rate higher capacities) If you have a Torqueedo battery whose capacity is indicated to be 2.7 kWh, you can use the full 2.7 kWh.

Service life and aging of lithium batteries:

Life expectancy of a lithium battery is driven by both age and number of cycles. In recreational use, cycles usually play a minor role as high usage cycles (>500) are never needed. Aging plays an important role, though, because lithium batteries age naturally after the date of production. Aging accelerates when a battery is exposed to high temperatures. Lithium batteries can be used in intense heat but they should be kept cool whenever possible. On average, a capacity loss of 4% per year can be expected.

SERRY
JACHTWERF

Oud-Loosdr. dijk 249 a-d
1231 LX Loosdrecht
Holland
Tel. 035-58 234 04
Fax 035-58 260 80
info@serry.com
www.serry.com

High-voltage drive systems

40 - 160 HP equivalents



54 Deep Blue

62 Deep Blue Hybrid



Deep Blue

It is the first and only one of its kind. More than just a battery-powered electric motor, Deep Blue is a fully integrated high power system – based on high-tech components, industrially engineered to meet the highest demands.

The result – exceptional performance, professional safety, compliance with international standards at the system level and extreme ease of operation. It comes as either a 40 HP or 80 HP equivalent in outboard, inboard or saildrive versions and with a 9-year limited warranty on battery capacity*.

- + The first high-performance electric drive system from serial production
- + Standards-compliant, fully integrated complete system
- + Best performance
- + Maximum convenience
- + Industry-standard professional safety
- + 9-year limited warranty on battery capacity
- + Available as outboard, inboard or saildrive

* After 9 years of use, the batteries will still have 80% of original capacity, even if used on a daily basis.



- _ Commercial users
- _ Boaters on "green lakes"
- _ Sailboats

40^{HP}
equivalent*

80^{HP}
equivalent*

160^{HP}
equivalent*

Deep Blue

*The high-performance
electric drive system*



* The propulsive power of our Deep Blue electric drives is equivalent to comparably rated petrol outboards. See pages 12/13.

Deep Blue System

The high-performance electric drive system from serial production. A fully integrated system whose high-tech components are carefully tailored to match each other and to work together perfectly on the water. Deep Blue has a modular, integrated design that is flexible and scalable. Deep Blue stands for performance, convenience and professional safety through industrial engineering.

High-voltage cables and plug connections with pilot line and insulation monitor. The pilot line and insulation monitor are safety features that protect the entire system from high-voltage damage at all times. What is standard on land for high-voltage equipment is unique to Torqeedo on the water.

AC connection box: Bundles all electric cables carrying AC voltage. Determines whether the system is being charged from onshore power (while at dock) or from a generator (while at sea). Waterproof to IP67.

Remote maintenance option via VPN connection

Electronic throttle: clean, slick design, with key switch, emergency-stop and neutral lock for safe operation. Power-trim-and-tilt for outboard operation. (See page 42/43 for throttle options)

Connection box: Bundles electric cables and signal lines. Waterproof to IP67 with integrated water sensor.

Deep Blue information system on high resolution marine display: touch-screen, waterproof, good sunlight readability. Clean, clearly arranged display of system information.



12 V battery: activates the high-voltage battery at each start-up. Supplies 12 V for the on-board network and is automatically charged from the high-voltage battery. No additional 12 V charger required.

Charger: Advanced engineering from the automotive industry. Waterproof to IP67. The charging rate can be controlled via the display. Multiple chargers possible per system - for shorter charging times.

High-voltage electric motor: Specially developed for the requirements of the Deep Blue system. Electronically commutated brushless motor with outstanding efficiency (max. 98%). Suitable for salt water cooling. Waterproof to IP67. Comes with NMEA2000 / J 1939 CAN interface.



BMW i battery: latest battery generation from BMW i3. Very high energy density, durable, robust, highest level of quality and safety.



Configure your own Deep Blue System

Deep Blue has been developed in a fully integrated yet modular way. Chose from various options to configure Deep Blue to match your requirements.

Motor options

Outboard, outboard tiller, shaft drive, saildrive

Throttle options

Side mount sail, side mount motor, top mount, top mount twin

Multiple batteries

Multiple chargers

Multiple throttles

Multiple motor systems

Solar integration

Generator integration

Energy management and hotel load integration





SERRY
JACHTWERF

Oud-Loosdr. dijk 249 a-d
1231 LX Loosdrecht
Holland
Tel. 035-58 234 04
Fax 035-58 260 80
info@serry.com
www.serry.com

Torqueedo high-performance motors as
40 HP or 80 HP equivalent

Deep Blue motors

Specifically developed for the requirements of the Deep Blue systems - maximum efficiency, long service life, low maintenance. Available in several models for different uses:

-  Electronically commutated brushless **motor with outstanding efficiency (98%)**
-  **Waterproof to IP67**
-  Suitable for **saltwater cooling**
-  Part of the fully integrated Deep Blue drive system

Deep Blue 40 R/T
Deep Blue 80 R/T



Deep Blue R/T models



The most powerful electric outboards from industrial serial production. R models provide control via electronic throttle, T models provide tiller control.

Available in two performance classes and as long shaft (RL/TL) and extra long shaft (RXL/TXL) versions.





Speed and range**

Deep Blue 40 with one 12.8 kWh battery

	Speed in knots (km/h)	Range in nm (km)	Running time in hh:mm
 Slow	4.0 (7.5)	20-32 (37-60)	05:00 - 08:00
 Full throttle	17-24 (32-44)	9-12 (16-22)	00:30

Deep Blue 80 with one 30.5 kWh battery

	Speed in knots (km/h)	Range in nm (km)	Running time in hh:mm
 Slow	4.0 (7.5)	24 -78 (44 - 144)	06:25 - 19:15
 Full throttle	19-29 (36-54)	12 -18 (22-33)	0:35

* The propulsive power of our electric drives is equivalent to comparably rated petrol outboards. See pages 12/13.

** Depends on type of boat, load, propeller and conditions. Speed and range indications do not represent a legal guarantee.



Deep Blue 40 SD

Deep Blue 40 SD

The highest-performance electric saildrive system from serial production. 25 kW input power, highest efficiency.



- + **Lightweight:** Saildrive with motor and electronics system 85 kg
- + **Space-saving design**
- + **Compatible with standard saildrive mounting flanges**

Deep Blue 40 i 1400 / Deep Blue 40 i 1800 Deep Blue 80 i 1400 / Deep Blue 80 i 1800

Deep Blue i models

The most powerful integrated drive system from serial production Available in two performance classes. Shaft drive at 1,800 or 1,400 rpm on the propeller shaft.



- + **Lightweight:** Inboard with motor and electronics system 85 kg
- + **Compact construction**
- + **Available in motor-speed versions of 1,800 rpm and 1,400 rpm**
- + **Suitable for saltwater cooling**

Speed and range**

Deep Blue 40 SD with one 30.5 kWh battery

	Speed in knots (km/h)	Range in nm (km)	Running time in hh:mm
● ● ● Slow	5.0 (9.3)	30 (55)	06:00
● ● ● Full throttle	10 (18.5)	12 (22)	01:15

Deep Blue 80 i 1800 with one 30.5 kWh battery

	Speed in knots (km/h)	Range in nm (km)	Running time in hh:mm
● ● ● Slow	4.0 (7.5)	24 -78 (44 - 144)	06:25 - 19:15
● ● ● Full throttle	19-29 (36-54)	12 -18 (22-33)	0:35

Professional safety

Safety standards for high-performance electric drives demand industrial engineering

Powerful electric propulsion systems require industrial-level safety and engineering. With its pioneering development of the Deep Blue System, Torqeedo has set the standard for safety in high-power electric boating. Other industries, such as high power machinery or automotive, offer well-established safety standards. But, simply adopting these standards is not sufficient. Due to their unique characteristics, marine drive systems require specific safety measures and must meet different challenges and norms than products from other industries.

Let's examine some of the elements of the Deep Blue safety system.

Honored with its very own insurance tariff

Electric drive systems are gaining ground - on land and on the water. Many systems on the market are one-off solutions from small companies without comprehensive engineering for safety. This results in a high rate of dangerous accidents and expensive insurance tariffs.

The comprehensive safety system and standards-compliance of Deep Blue has been recognized by PANTAENIUS, Europe's leading yacht insurance company with a special, lower insurance tariff that provides more comprehensive protection.



The **insulation monitor** constantly monitors that the voltage from all high-voltage components is completely isolated from the boat - not just for individual system components but for all of them. If damage is detected, e.g. to the cable insulation, the system will issue an alert. In the event of dangerous insulation failure, the system will be shut down.



The **pilot line** monitors all high-voltage plug connections on the Deep Blue. It will shut off the system immediately if it detects exposed high-voltage contacts in order to avoid any risk. Pilot lines have been mandatory for high-voltage equipment in other industries. They are not typically found in high-voltage, made-to-order boat drives.



Automotive industry-level battery safety: The first lithium batteries for the marine industry with the advanced quality standards of the automotive sector are the result of Torqeedo's collaboration with established battery manufacturers. Torqeedo has been cooperating with BMW i since autumn 2016. Integrating a battery into a drive system and the associated safety concept alone requires considerable effort that can only be achieved by working together with the battery manufacturer.



All components are waterproof: Components that were not specifically developed for boats are not always waterproof. All the components of a high-voltage system on a boat must be waterproof to guarantee safe operation. That is why all of our components are waterproofed and, in some cases, are further protected with water sensors.



Battery venting: In the unlikely event that the redundant safety mechanisms of the battery fail, the battery cells can reduce their temperature and pressure via a pressure valve. While batteries are installed in electric cars in such a way that they can discharge battery gases directly onto the road, on electric boats the gases must be channelled safely off the vessel. We developed the first safe venting system for boats for the Deep Blue System.



Battery damping: All components on fast and seagoing boats are subject to constant high levels of shock that exceed shock levels on the road - in some cases over 12 g of acceleration force. Since batteries and battery electronics are not designed for these constant impacts, they need their own damping system on boats (in addition to the damping mechanisms within the battery). Torqeedo is the only company in the world that provides this for maritime use.

It all adds up

*Flat fee boating -
economical electric mobility
for commercial operators
and frequent users*

Deep Blue can save you money if your annual fuel costs exceed EUR 4,500

Are your fuel costs higher than EUR 4,500 per year? If they are, it might be worth switching to Deep Blue today. Deep Blue protects you from changing fuel costs; electricity prices are more stable and much less expensive. At the same time, you will set an example of good financial sense while demonstrating how we can retain mobility in increasingly difficult ecological conditions - more quietly, cleanly and with respect for nature.

9-year warranty on battery capacity

The economic case for electric boating depends on a reliable battery service life. That is why the Deep Blue battery comes with a long-term battery capacity warranty: 9 years after commissioning, the batteries will still have 80 % of their original capacity, even if you use them every day.* The battery life cycle is transparent and can be tracked by the user in the on-board computer at any time.

Transparent maintenance costs

An electric drive system requires less maintenance than comparable drive systems using fossil fuel.

A better user experience for passengers and better working conditions for crew members

Electric excursion boats, water taxis and ferries provide passengers with a better user experience, offering quiet, convenient and emission-free transport. For crew members, who operate boats several hours per day, electric boats offer substantially better working conditions, exposing them to considerably less noise, exhaust and smell.



Model	Deep Blue 40	Deep Blue 80	Deep Blue 80
Number of batteries	1	1	2
Battery bank capacity in kWh	12.8	30.5	61
Investments			
System (MSRP in EUR, without batteries)	19,999	19,999	19,999
Battery bank (MSRP in EUR)	15,499	25,499	50,998
Battery and electricity costs			
Annual battery costs in EUR**	2,142	3,524	7,048
Electricity cost per kWh in EUR***	0.257	0.257	0.257
Cost for one charge (80%) in EUR	2.63	6.27	12.54
Total annual battery and electricity costs for 150 usage cycles per year	2,537	4,465	8,929
Total annual battery and electricity costs for 200 usage cycles per year	2,668	4,778	9,556

If annual fuel costs exceed these values, switching to an electric drive system may make sense for you.

* Warranty terms apply. Find out details at www.torqueedo.com.

** Assuming financing at an annual interest rate of 5% over the warranty period (9 years).

*** Cost level in Germany. Electricity costs are significantly lower in most other countries - e.g. France, UK, USA.

Deep Blue Hybrid

Deep Blue Hybrid integrates propulsion and energy management into one complete system.

Deep Blue Hybrid uses energy from various sources – clean power from solar modules and hydro-generation while under sail, shore power and, when necessary, energy from modern and efficient diesel generators. The energy obtained from different sources is managed and distributed to power all electrical devices on board – the main drive system, tender and on-board electronics as well as all hotel loads, from the air conditioning to the water maker.

Luxury meets sustainability

- + Powerful and silent electric propulsion
- + Abundance of energy to power everything on board - with less pollution
- + Silent power generation from the wind and the sun
- + Only one type of fuel on board - and less of it
- + More freedom, pioneering mobility



- _ Sailboats between 40 and 80 feet
- _ Commercially operated hybrid boats
- _ Water taxis and ferries

40^{HP}
equivalent*

80^{HP}
equivalent*

160^{HP}
equivalent*

Deep Blue Hybrid

*Clean electric propulsion and
Energy Management 2.0*

* The propulsive power of our electric drives is equivalent to comparably rated petrol outboards. See pages 12/13.

Energy Management 2.0

Chart your own course with Deep Blue Hybrid

- + First hybrid system with **powerful electric propulsion** (25 - 100 kW continuous power)
- + **Fully integrated system**
- + Flexible and scalable through **modular design**
- + **Industrial engineering** and production
- + **Standards-compliant** at system level
- + International **warranty**
- + **Remote diagnostics, remote upgrade and remote maintenance**
- + **International service network**



Power supply

- 1 Hydro-generation** - the electric drive system can be used to generate power while under sail.
- 2 Onshore power connection.** The large battery bank can be recharged with sufficient energy for the voyage when in port.
- 3 Efficient state-of-the-art diesel generator.** Only runs when power requirements exceed the renewable sources and available battery capacity. Runs at optimum operating point feeding the high-voltage system directly.
- 4 Photovoltaic modules** generate power from solar energy.

Storage and conversion

- 1 345 V high-voltage lithium battery system**
- 2 24 V on-board power lithium battery system**
- 3 Bi-directional DC/DC converter**
- 4 DC/AC inverter**

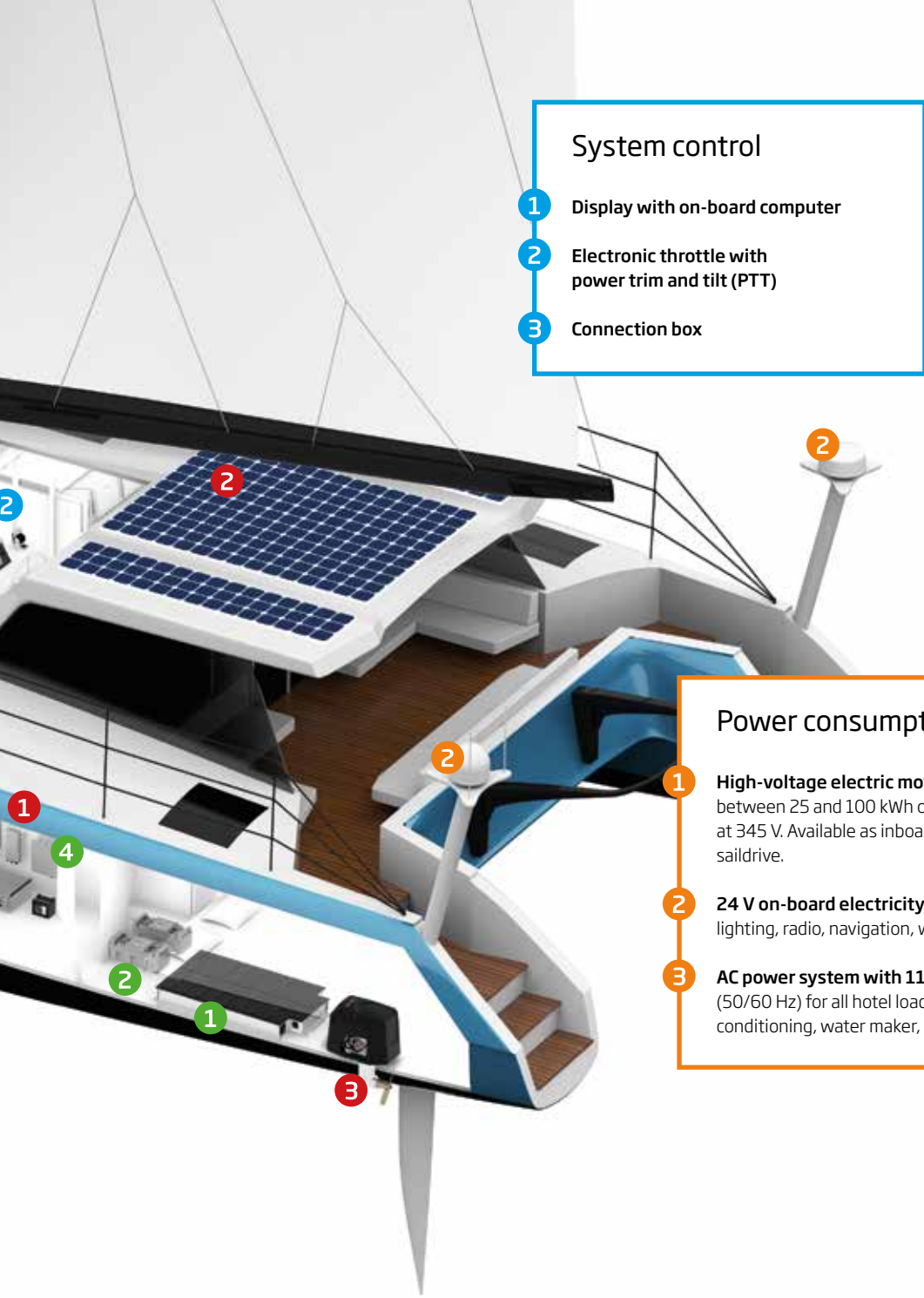

System control

- 1 Display with on-board computer
- 2 Electronic throttle with power trim and tilt (PTT)
- 3 Connection box

Power consumption

- 1 **High-voltage electric motor** - delivers between 25 and 100 kWh of continuous power at 345 V. Available as inboard, outboard or saildrive.
- 2 **24 V on-board electricity** for equipment like lighting, radio, navigation, winches etc.
- 3 **AC power system with 110 or 230 V** (50/60 Hz) for all hotel loads on board like air conditioning, water maker, galley, etc.

Components - technical data

Scalable design allows installation of one or more of each component.

Motors: outboards	Deep Blue 40	Deep Blue 80
Output (peak)	33 kW	66 kW
Output (continuous)	25 kW	50 kW
Torque	205 Nm	205 Nm
Weight (incl. electronics)	from 139 kg	from 139 kg

Motors: inboards	Deep Blue 40i	Deep Blue 80i
Output (peak)	33 kW	60 kW
Output (continuous)	25 kW	50 kW
Torque	1,400: 350 Nm / 1,800: 280 Nm	
Weight (incl. electronics)	85 kg	85 kg

Motors: saildrives	Deep Blue 40 SD
Output (peak)	33 kW
Output (continuous)	25 kW
Torque	180 Nm
Weight (incl. electronics)	85 kg

Generator	
Output (peak)	25 kW
Output (continuous)	25 kW
Weight (including sound insulation)	260 kg

Batteries	High-voltage	Low-voltage
Capacity	33 kWh	2.7 kWh
Voltage	345 V	26 V
Weight	256 kg	24 kg

Inverter	DC-AC
Output power	6 kW
Weight	25 kg

Further components	Solar charge controller	High-voltage charger
Output power	0.2 kW	3 kW
Weight	0.3 kg	4 kg + heat dissipation plate (6 kg)

Connection box	
Weight	10 kg

Always in control

Deep Blue Hybrid offers intuitive operation presented on the multi-functional display, providing a complete overview of the entire system and access to all control

functions. The software keeps an eye on everything and prevents errors like deep-discharging batteries. Available with GUI for multihulls or monohulls.



Main menu
navigate easily between different categories



Drive screen:
all important information needed while motoring. You can choose to display or hide the information line at the top.

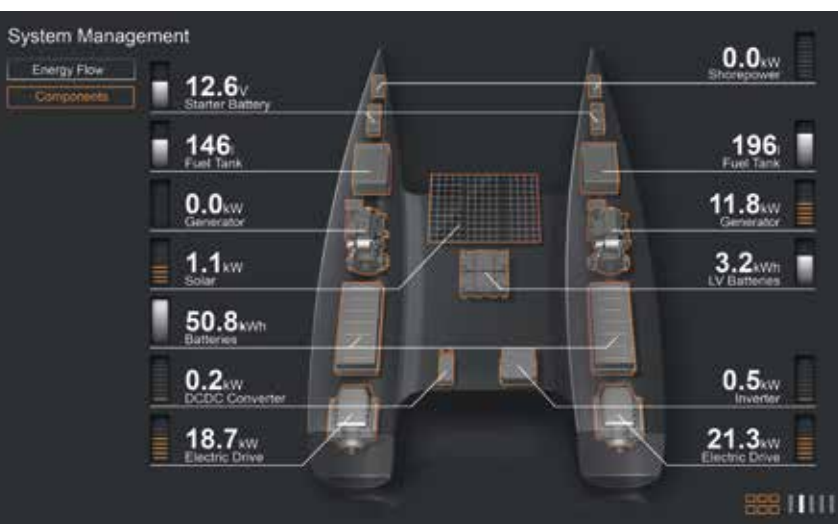

System management: provides status data on all system components. Select individual components for more detail.

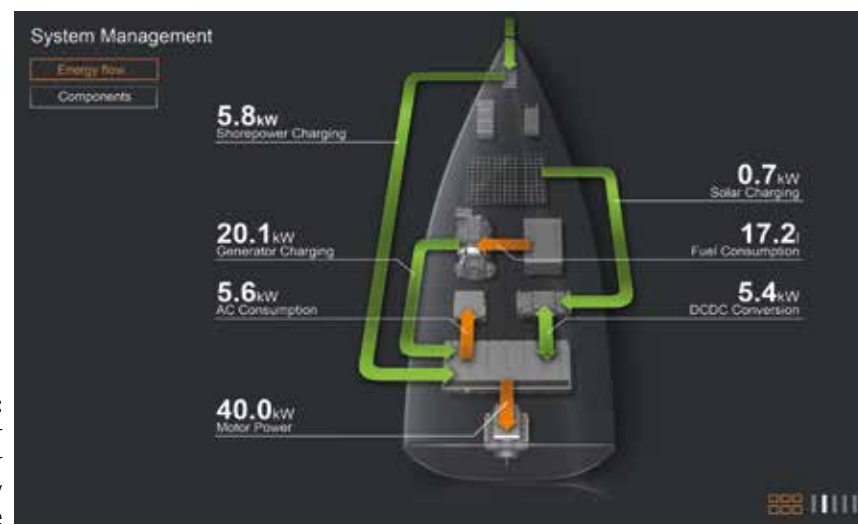

Energy flow:
Understand your system's power balance and energy flow at a glance

25 kW Range Extender **NEW**

*Quiet, lightweight, efficient –
the first inverter generator for
serial hybrid marine applications*

The situation

Conventional generators operate at a fixed ratio between rotation speed, power output and voltage output. This means substantial disadvantages for marine use:

1. Typically, hotel loads on a boat require low power outputs - often below the efficient operating points of the generator.
2. When used as a range extender for hybrid drives, the generator's task is to recharge depleted batteries, slowly passing through the whole voltage range of the battery. This means the generator may work inefficiently for an extended part of the time. An additional issue is that conventional generators will not deliver their nominal power when they operate on relatively low voltage levels. This is problematic, because low voltage levels occur when batteries are empty and full generator power may be urgently needed.

The new generation of inverter generators gets rid of the fixed ratio between rotation speed, power and voltage output. Using power electronics, they can produce all required combinations of power and voltage while the combustion engine runs at its optimal operating point. However, inverter generators available today provide only AC power and relatively low power levels, so they are not suited to support serial hybrid systems.



The innovation

With our 25 kW Range Extender, Torqeedo introduces the first inverter generator capable of supplying electricity for yachts and supporting serial hybrid systems. The combustion engine always runs at its most efficient operating point and can supply the full 25 kW - regardless of fluctuating hotel load demands or the voltage level of the Deep Blue batteries. It features a digital signal processor unit with complex signal processing and high computing capacity. Its DC power output charges the batteries of the Deep Blue System directly for maximum efficiency.

Another innovation: the 25 kW Range Extender does not require a separate starter. This job is taken over by the electric motor included in the gen-set. As the integrated electric motor is a lot stronger than an ordinary starter,

the combustion engine can join in at a far higher rotational speed and a more efficient working point. This means less pollutant emission, less vibration and a longer life for the combustion engine.

The 25 kW Range Extender was specifically designed to efficiently power the Deep Blue system and is fully integrated into the information and safety systems of Deep Blue Hybrid.

Technical data Outboards & Pods ≤ 20 HP equivalent

	ULTRALIGHT 403	TRAVEL 503 S/L	TRAVEL 1003 S/L	TRAVEL 1003 C S/L	CRUISE 2.0 TS/TL	CRUISE 4.0 TS/TL
Input power in watts	400	500	1,000	1,000	2,000	4,000
Propulsive power in watts	180	240	480	480	1,120	2,240
Comparable petrol outboard (shaft power)	1 HP	1.5 HP	3 HP	3 HP	5 HP	8 HP
Comparable petrol outboard (thrust)	2 HP	2 HP	4 HP	4 HP	6 HP	9.9 HP
Maximum overall efficiency in %	45	48	48	48	56	56
Static thrust in lbs*	33	40	68	68	115	189
Integrated battery	320 Wh Li-Ion	320 Wh Li-Ion	530 Wh Li-Ion	915 Wh Li-Ion	-	-
Nominal voltage	29.6	29.6	29.6	29.6	24	48
Final charging voltage	33.6	33.6	33.6	33.6	-	-
Total weight in kg	8.9	13.9(S) / 14.5(L)	14.4(S) / 15.0(L)	14.9 (S) / 15.5 (L)	17.5 (S) / 18.6 (L)	18.3 (S) / 19.4 (L)
Motor weight without battery, in kg	4.4	8.9 (S) / 9.5 (L)	8.9 (S) / 9.5 (L)	8.9 (S) / 9.5 (L)	-	-
Weight of integrated battery, in kg	4.5	5.0	5.5	6.0	-	-
Shaft length in cm	45	62.5 (S) / 75 (L)	62.5 (S) / 75 (L)	62.5 (S) / 75 (L)	62.4 (S) / 74.6 (L)	62.4 (S) / 74.6 (L)
Standard propeller (v = speed in km/h at p = power in watts)	v10/p350	v9/p790	v9/p790	v9/p790	v19/p4000	v19/p4000
Alternative propeller options	-	v8/p350	-	-	v8/p350 v30/p4000	v8/p350 v30/p4000
Maximum propeller speed in rpm at full load	1,200	700	1,200	1,200	1,300	1,300
Control	Throttle	Tiller	Tiller	Tiller	Tiller	Tiller
Steering	Provision to connect to kayak rudder; lockable	360° lockable	360° lockable	360° lockable	360° lockable	360° lockable
Tilting device	Manual, with impact protection	Manual, with impact protection	Manual, with impact protection	Manual, with impact protection	Manual, with impact protection	Manual, with impact protection
Trim device	-	Manual, 4-step	Manual, 4-step	Manual, 4-step	Manual, 4-step	Manual, 4-step
Stepless forward/ reverse drive	Yes	Yes	Yes	Yes	Yes	Yes
Integrated on-board computer with display	Yes	Yes	Yes	Yes	Yes	Yes

*Torqeedo static thrust measurement is based on internationally accepted ISO standards. Static thrust figures for conventional trolling motors are typically measured differently, which results in higher values. To compare Torqeedo static thrust data with conventional trolling motors, add approximately 50% to the Torqeedo static thrust values.

CRUISE 2.0 RS/RL	CRUISE 4.0 RS/RL	CRUISE 10.0 R	TWIN CRUISE 2.0 R	TWIN CRUISE 4.0 R	CRUISE 2.0 FP	CRUISE 4.0 FP	CRUISE 10.0 FP
2,000	4,000	10,000	4,000	8,000	2,000	4,000	10,000
1,120	2,240	5,600	2,240	4,480	1,120	2,240	5,600
5 HP	8 HP	20 HP	8 HP	15 HP	5 HP	8 HP	20 HP
6 HP	9.9 HP	25 HP	12 HP	20 HP	6 HP	9.9 HP	25 HP
56	56	56	56	56	56	56	56
115	189	315	230	378	115	189	315
-	-	-	-	-	-	-	-
24	48	48	24	48	24	48	48
-	-	-	-	-	-	-	-
15.3 (S) / 16.2 (L)	16.1 (S) / 17.0 (L)	59.8 (S) / 61.3 (L) / 62.5 (XL)	31.0 (S) / 33.1 (L)	32.5 (S) / 34.5 (L)	15.4	15.8	33.5
-	-	-	-	-	-	-	-
-	-	-	-	-	-	-	-
62.4 (S) / 74.6 (L)	62.4 (S) / 74.6 (L)	38.5 (S) / 51.2 (L) / 63.9 (XL)	62.4 (S) / 74.6 (L)	62.4 (S) / 74.6 (L)	-	-	-
v19/p4000	v19/p4000	v32/p10k	v19/p4000	v19/p4000	v19/p4000	v19/p4000	v32/p10k
v8/p350 v30/p4000	v8/p350 v30/p4000	v15/p10k	v8/p350 v30/p4000	v8/p350 v30/p4000	v13/p4000 (folding propeller)	v13/p4000 (folding propeller)	v15/p10k (folding propeller)
1,300	1,300	1,400	1,300	1,300	1,300	1,300	1,400
Throttle	Throttle	Throttle	Throttle	Throttle	Throttle	Throttle	Throttle
Provision to connect to standard remote steering; lockable	Provision to connect to standard remote steering; lockable	+/-65°, lockable	Provision to connect to standard remote steering; lockable	Provision to connect to standard remote steering; lockable	-	-	-
Manual, with impact protection	Manual, with impact protection	Power tilt with impact protection	Manual, with impact protection	Manual, with impact protection	-	-	-
Manual, 4-step	Manual, 4-step	Manual, 4-step	Manual, 4-step	Manual, 4-step	-	-	-
Yes	Yes	Yes	Yes	Yes	Yes	Yes	Yes
Yes	Yes	Yes	Yes	Yes	Yes	Yes	Yes

Technical data Outboards & inboards 40 / 80 HP equivalents

DEEP BLUE SYSTEM	DEEP BLUE 40 RL / RXL	DEEP BLUE 80 RL / RXL	DEEP BLUE 40 TL / TXL	DEEP BLUE 80 TL / TXL	DEEP BLUE 40i 1800/1400	DEEP BLUE 80i 1800/1400	DEEP BLUE 40 SD
Peak input power in kW	33	66	33	66	33	66	33
Input power (continuous) in kW	25	50	25	50	25	50	25
Propulsive power in kW	16.2	32.4	16.2	32.4	> 16.2	> 32.4	16.2
Comparable petrol outboard (shaft power)	40 HP	80 HP	40 HP	80 HP	40 HP	80 HP	-
Comparable combustion engine	-	-	-	-	-	-	40 HP
Maximum overall efficiency in %	54	54	54	54	> 54	> 54	54
Integrated battery: usable energy in kWh	12.8	30.5	12.8	30.5	12.8	30.5	30.5
Nominal voltage	345 V	345 V	345 V	345 V	345 V	345 V	345 V
Final charging voltage	389 V	389 V	389 V	389 V	389 V	389 V	389 V
Motor weight including electronics (without battery) in kg	139 (L) / 145 (XL)	139 (L) / 145 (XL)	145 (L) / 151 (XL)	145 (L) / 151 (XL)	85	85	85
Weight of 1 battery in kg	149	256	149	256	149	256	256
Total system weight in kg - example (long shaft version, 1 charger, connection box, display, throttle and cabling)	313 (with 1 battery, 12.8 kWh)	420 (with 1 battery)	319 (with 1 battery, 12.8 kWh)	426 (with 1 battery)	254 (with 1 battery, 12.8 kWh)	370 (with 1 battery)	370 (with 1 battery)
Shaft length	20" / 51 cm (L) 25" / 63.5 cm (XL)	20" / 51 cm (L) 25" / 63.5 cm (XL)	20" / 51 cm (L) 25" / 63.5 cm (XL)	20" / 51 cm (L) 25" / 63.5 cm (XL)	-	-	± 36.2 cm
Standard propeller	v50/p50k	v50/p50k	v50/p50k	v50/p50k	-	-	Boat-specific
Maximum propeller speed in rpm at full load	2,400	2,400	2,400	2,400	1,800 / 1,400	1,800 / 1,400	1,200
Control	Throttle	Throttle	Tiller with throttle	Tiller with throttle	-	-	Throttle
Tilting device	Power trim and tilt	Power trim and tilt	Combined trim and tilt switch (on the tiller)	Combined trim and tilt switch (on the tiller)	-	-	-
Trim device	Power trim and tilt	Power trim and tilt	Combined trim and tilt switch (on the tiller)	Combined trim and tilt switch (on the tiller)	-	-	-
Integrated on-board computer with touchscreen display	Yes	Yes	Yes	Yes	Yes	Yes	Yes

Ordering information

Part no.	Product	Description
----------	---------	-------------

Drives & batteries

ULTRALIGHT

1404-00	Ultralight 403	Ultralight outboard, 1 HP equivalent, with integrated 320 Wh high-performance lithium battery, including charger, throttle, on-board computer, GPS-based range calculation and emergency magnetic kill switch
1416-00	Spare battery Ultralight 403, 320 Wh	High-performance lithium battery with integrated GPS receiver, 320 Wh, 29.6 V, 11 Ah. With USB port for charging other devices
1417-00	Spare battery Ultralight 403, 915 Wh NEW	High-performance lithium battery with integrated GPS receiver, 915 Wh, 29.6 V, 31 Ah. With USB port for charging other devices

TRAVEL

1140-00	Travel 503 S	High-efficiency outboard with integrated 320 Wh high-performance lithium, 1.5 HP equivalent, including on-board computer with GPS-based range calculation, charger, emergency magnetic kill switch, short shaft
1141-00	Travel 503 L	As part no. 1140-00, but with long shaft
1142-00	Travel 1003 S	High-efficiency outboard with integrated 530 Wh high-performance lithium, 3 HP equivalent, including on-board computer with GPS-based range calculation and charger, emergency magnetic kill switch, short shaft
1143-00	Travel 1003 L	As part no. 1142-00, but with long shaft
1149-00	Travel 1003 CS NEW	High-efficiency outboard with integrated 915 Wh high-performance lithium, 3 HP equivalent, including on-board computer with GPS-based range calculation and charger, emergency magnetic kill switch, short shaft
1150-00	Travel 1003 CL NEW	As part no. 1149-00, but with long shaft
1147-00	Spare battery Travel 1003/503, 530 Wh	High-performance lithium battery with integrated GPS receiver, 530 Wh, 29.6 V, 18 Ah. With USB port for charging other devices
1148-00	Spare battery Travel 1003/503, 915 Wh NEW	High-performance lithium battery with integrated GPS receiver, 915 Wh, 29.6 V, 31 Ah. With USB port for charging other devices

CRUISE

1234-00	Cruise 2.0 TS	High-efficiency outboard, 5-6 HP equivalent. With tiller steering, integrated on-board computer with GPS-based range calculation, 25 mm ² cable set (3 m) including fuse and main switch, short shaft version
1235-00	Cruise 2.0 TL	As part no. 1234-00, but with long shaft

Part no.	Product	Description
1236-00	Cruise 4.0 TS	High-efficiency outboard, 8-9.9 HP equivalent. With tiller steering, integrated on-board computer with GPS-based range calculation, 25 mm ² cable set (3 m) including fuse and main switch, short shaft version
1237-00	Cruise 4.0 TL	As part no. 1236-00, but with long shaft
1230-00	Cruise 2.0 RS	High-efficiency outboard, 5-6 HP equivalent. Includes connection to remote steering, throttle, integrated on-board computer with GPS-based range calculation, 25 mm ² cable set (3 m) including fuse and main switch, short shaft version
1231-00	Cruise 2.0 RL	As part no. 1230-00, but with long shaft
1232-00	Cruise 4.0 RS	High-efficiency outboard, 8-9.9 HP equivalent. Includes connection to remote steering, throttle, integrated on-board computer with GPS-based range calculation, 25 mm ² cable set (3 m) including fuse and main switch, short shaft version
1233-00	Cruise 4.0 RL	As part no. 1232-00, but with long shaft
1240-00	Cruise 10.0 RS	High-efficiency outboard, 20 HP equivalent. Includes connection to remote steering, throttle, integrated on-board computer with GPS-based range calculation, 70 mm ² cable set (4.5 m) including fuse and main switch, plug connector, short shaft version
1241-00	Cruise 10.0 RL	As part no. 1240-00, but with long shaft
1242-00	Cruise 10.0 RXL	As part no. 1240-00, but with extra-long shaft
1250-00	Cruise 2.0 FP	High-efficiency pod motor (fixed position), 5-6 HP equivalent. Includes throttle, integrated on-board computer with GPS-based range calculation, 25 mm ² cable set (3 m) including fuse and main switch, with weedless propeller
1251-00	Cruise 4.0 FP	High-efficiency pod motor, fixed position, 8-9.9 HP equivalent. Includes throttle, integrated on-board computer with GPS-based range calculation, 25 mm ² cable set (3 m) including fuse and main switch, with weedless propeller
1252-00	Cruise 10.0 FP	High-efficiency pod motor (fixed position), 20 HP equivalent. Includes throttle, integrated on-board computer with GPS-based range calculation, 70 mm ² cable set (4.5 m) including fuse and main switch, plug connector
1217-00	Twin-Cruise Extension set	For twin motors based on Cruise 2.0 R or 4.0 R models, consisting of aluminium dual throttle with dual information display and 56 cm tie bar
1905-00	Anode Al Cruise 2.0/4.0 R/T/FP	Anode for operating 2.0/4.0 models with standard propeller (with part no. 1915-00, 1916-00, 1923-00, 1933-00, 1953-00). Attachment to motor shaft, made from aluminium, for use in fresh water
1939-00	Anode Zn Cruise 2.0/4.0 R/T/FP NEW	Anode for operating 2.0/4.0 models with standard propeller (with part no. 1915-00, 1916-00, 1923-00, 1933-00, 1953-00). Attachment to motor shaft, made from zinc, for use in seawater

Part no.	Product	Description
1941-00	Anode set Al Cruise 2.0/4.0 FP NEW	Anode set for Cruise 2.0/4.0 FP models with folding propeller (with part no. 1932-00). Consists of 2 ring anodes for attachment to the propeller and 1 anode for attachment to the pylon, made from aluminium, for use in fresh water
1942-00	Anode set Zn Cruise 2.0/4.0 FP NEW	Anode set for Cruise 2.0/4.0 FP models with folding propeller (with part no. 1932-00). Consists of 2 ring anodes for attachment to the propeller and 1 anode for attachment to the pylon, made from zinc, for use in seawater
1935-00	Anode set Al Cruise 10.0 R NEW	Anode set made from aluminium for use with Cruise 10.0 R in fresh water, consists of 1 shaft anode, 2 half-ring anodes, 2 ring anodes
1936-00	Anode set Zn Cruise 10.0 R NEW	Anode set made from zinc for use with Cruise 10.0 R in seawater, consists of 1 shaft anode, 2 half-ring anodes, 2 ring anodes
1947-00	Anode set Al Cruise 10.0 FP NEW	Anode set for Cruise 10.0 FP models with folding propeller (with part no. 1945-00). Consists of 2 ring anodes for attachment to the propeller and 1 anode for attachment to the pylon, made from aluminium, for use in fresh water
1948-00	Anode set Zn Cruise 10.0 FP NEW	Anode set for Cruise 10 FP models with folding propeller (with part no. 1945-00). Consists of 2 ring anodes for attachment to the propeller and 1 anode for attachment to the pylon, made from zinc, for use in seawater

POWER

2103-00	Power 26-104	High-performance lithium battery, 2,685 Wh, rated voltage 25.9 V, charge 104 Ah, weight 24.3 kg, with innovative battery management system including numerous protective functions, waterproof to IP67; includes: cable for communication with Cruise system
2206-20	Charger 350 W for Power 26-104	Charge current 10 A, charges the Power 26-104 from 0 to 100% in a maximum of 11 hours, waterproof to IP65
2210-00	Fast charger 1,700 W for Power 26-104	Charge current 60 A, charges the Power 26-104 from 0 to 100% in < 2 hours, waterproof to IP65
2304-00	On/off switch for Power 26-104	Switch for activating/deactivating the Power 26-104, IP65, with LED on/off status display; the on/off switch is required when the Power 26-104 is used without a Cruise system
1934-00	Spare cable bridges Cruise NEW	Cable set for connecting 2 additional Power 26-104 to a battery bank; consists of 1 serial cable, 40 cm, 35 mm ² with pole shoe connector, 4 potential equalisation cables including M12 nuts, 40 cm, 35 mm ² with ring terminal connector M12, 2 data cables, 1.5 m with waterproof data plug connectors

Part no.	Product	Description
2207-00	Solar charge controller for Power 26-104	Specially adapted to the Power 26-104 Enables the Power 26-104 to be charged with solar energy. (Solar modules not included.) Integrated MPPT maximises the energy yield of the solar modules during charging, very high level of efficiency. Maximum output power 232 watts (8 A, 29.05 V)
2211-00	Fast solar charge controller for Power 26-104 NEW	Specially adapted to the Power 26-104 Enables the Power 26-104 to be charged with solar energy. (Solar modules not included.) Integrated MPPT maximises the energy yield of the solar modules during charging, very high level of efficiency.

Accessories

EXTRAS

1925-00	Travel bags (2-piece)	For transporting / storing Travel 503/1003 models. Includes 2 bags - one bag for the motor (including tiller and accessories) and one bag for the battery.
1926-00	Travel battery bag	For transporting and storing Travel 503/1003 replacement batteries.
1931-00	Protective cover Travel	For Travel 503/1003 Protects the motor cable from UV fading and the shaft head from dirt. Water-resistant and breathable
1924-00	TorqTrac	Smartphone app for Travel 503/1003, Cruise T/R as well as Ultralight models Allows larger display of the on-board computer showing range on map and with many other benefits. Requires a Bluetooth Low Energy®-capable smartphone
6503-00	Men's softshell jacket	Dark blue with appliqué decoration Hood, three zipper pockets, zip fastener at the front. Breathable, wind- and water-resistant (3-layer membrane). Material: 100% polyester. Sizes: S, M, L, XL, XXL, XXXL
6502-00	Men's polo shirt	Grey mélange with appliqué decoration. High-quality piqué made from pure cotton. Buttons and collar Sizes: S, M, L, XL, XXL, XXXL
6501-00	Men's T-shirt	White with print. Material: 100% cotton. Sizes: S, M, L, XL, XXL, XXXL

CHARGING EQUIPMENT

1132-00	Sunfold 50	Foldable 50 W solar panel, handy format, highly efficient, plug-&-play connections for waterproof charging of the Travel 503/1003 models and Ultralight 403, only compatible with battery part no. 1146-00, 1147-00, 1148-00, 1416-00 and 1417-00
---------	------------	---------------------------------------------------------------------------------------------------------------------------------------------------------------------------------------------------------------------------------------------------

Part no.	Product	Description
1130-00	Solar charger 45 W	Roll-out solar module, extremely weather-resistant and specially made for use on water. Plug-&-play connections for waterproof charging of Travel battery part no. 1144-00 and 1145-00 and Ultralight battery part no. 1413-00. Includes protective cover for easy transport and storage Discontinued model – available while stocks last
1133-00	Charger 90 W for Travel and Ultralight batteries	90 watt charger for electric sockets rated 100- 240 V and 50-60 Hz. For use only with batteries part no. 1146-00, 1147-00, 1148-00, 1416-00 and 1417-00
1127-00	Charger 40 W for Travel and Ultralight batteries	40 watt charger for electric sockets rated 100-240 V and 50-60 Hz. For use only with Travel 503/1003 and Ultralight 403 batteries
1131-00	Fast charger Travel 503/1003 (C) and Ultralight 403	120 watt charger for electric sockets rated 100-240 V and 50-60 Hz. For use only with batteries part no. 1144-00, 1145-00 and 1413-00

PROPELLERS & FINS

1912-00	Replacement propeller v10/p350	For Ultralight models 402 and 403 (Ø 200 mm)
1917-00	Replacement propeller v9/p790	For models Travel 1003 (C) and Travel 503 from 2014 (Ø 292 mm)
1915-00	Replacement propeller v8/p350	For Cruise 2.0/4.0 models manufactured from 2009 onwards, slower speed, lower effectiveness, greater thrust (Ø 300 mm).
1916-00	Replacement propeller v19/p4000	For Cruise 2.0/4.0 models manufactured from 2009 to 2016, faster, more effective, weedless (Ø 300 mm)
1933-00	Replacement propeller v19/p4000 NEW	For Cruise 2.0/4.0 models manufactured from 2017 onwards, faster, more efficient, weedless (Ø 300 mm).
1923-00	Replacement propeller v30/p4000	High-speed propeller for Cruise 2.0/4.0 R/T models manufactured from 2009 to 2016, for planing with light boats (Ø 320 mm)
1953-00	Replacement propeller v30/p4000 NEW	High-speed propeller for Cruise 2.0/4.0 models manufactured from 2017 onwards, for planing with light boats (Ø 320 mm)
1901-00	Replacement propeller v8/p350	For models Travel 401, 801 and 503, Base Travel and Cruise models (manufactured 2006-2008 (Ø 300 mm)
1932-00	Folding propeller v13/p4000	for use with Cruise 2.0/4.0 FP models on sailboats
1937-00	Replacement propeller v15/p10k NEW	For all Cruise 10.0 models, optimised for high thrust and displacement sailing, weedless
1938-00	Replacement propeller v32/p10k NEW	Speed propeller for all Cruise 10.0 models, optimised for planing
1945-00	Folding propeller v15/p10k NEW	for use with Cruise 10.0 FP model on sailboats
9145-00	Fin for Travel 503/1003 (C)	Protects the outboard when running aground
9234-00	Fin for Cruise R/T	Protects the outboard when running aground, for Cruise models with part no. 1209-00 to 1223-00

Part no.	Product	Description
9258-00	Fin for Cruise R/T	Aluminium fin coated in polyurethane (PU) foam for Cruise models with part no. 1230-00 to 1237-00. Better protection when running aground
9259-00	Fin for Cruise 10.0 R NEW	Protects the outboard when running aground

CABLE, CONTROL, STEERING

1918-00	Throttle for Travel 503/1003 (C) (Spare part for Cruise models, Ultralight 403)	Enables operation with throttle instead of tillers for models Travel 503/1003, including integrated display with information on battery status, GPS-based speed and remaining range calculation, including 1.5 m and 5 m connecting cables between motor and throttle. Can also be used as a spare part for Cruise and Ultralight models
1949-00	Throttle Sail side mounting NEW	Electronic throttle for sailboats, with on/off switch, emergency magnetic kill switch and 1.28" display
1950-00	Throttle side mounting NEW	Electronic throttle for motorboats, with power trim and tilt, key switch, magnetic kill switch and 1.28" display
1951-00	Throttle top mounting NEW	Electronic throttle, with power trim and tilt, key switch, magnetic kill switch and 1.28" display
1952-00	Dual throttle top mounting NEW	Electronic throttle, with power trim and tilt, key switch, magnetic kill switch and 1.28" display
1919-00	Long tiller arm	60 cm tiller tube extension, for Travel and Cruise T models
1920-00	Motor cable extension for Travel and Ultralight	Cable connection extension between battery and motor for the models Ultralight 403 and Travel 503/1003, allows a greater distance (2 m) between battery and motor, with waterproof plug connections
1204-00	Motor cable extension Cruise	Extension for Cruise cable set (between motor and battery), 2 m long, with high-voltage plug connector.
1921-00	Cable extension for throttle, 1.5 m	Extension cable for Travel 503/1003, Ultralight and Cruise models, allows a greater distance between throttle / tiller and motor
1922-00	Cable extension for throttle, 5 m	As part no. 1921-00, 5 m length
1914-00	Emergency magnetic kill switch	Emergency stop key and immobiliser for Travel, Cruise and Ultralight models
1927-00	Spare parts set Travel	Set for Travel consisting of emergency a kill switch, battery attachment pin and steering attachment pin
1940-00	Cable bridges for AGM/gel batteries NEW	Cable bridges for running Cruise 10.0 with AGM/gel batteries. Consists of: 4 cables, 40 cm, 35 mm ² with pole shoe connector
1128-00	12/24 V charger cable for Travel 503/1003 (C) and Ultralight 403	Allows the Travel 503/1003 (C) models and the Ultralight 403 to be charged from a 12/24 V power source

A global network



Torqueedo service centres

Torqueedo GmbH
Friedrichshafener Str. 4a
82205 Gilching
Germany
T +49 (0) 8153 - 92 15 - 126
F +49 (0) 8153 - 92 15 - 329
service@torqueedo.com

Torqueedo Inc.
171 Erick Street, Unit D-2
Crystal Lake, IL 60014
USA
T +1 - 815 - 444 8806
F +1 - 815 - 444 8807
service_usa@torqueedo.com

Torqueedo sales organisations

Torqueedo Germany, Austria, Switzerland

T +49 (0) 8153 - 92 15 - 100
info@torqueedo.com

Torqueedo United Kingdom / Ireland

T +44 (0) 1502 - 516 224
uk@torqueedo.com

Torqueedo North America

T +1-815-444-8806
usa@torqueedo.com

All other countries

Torqueedo GmbH
Friedrichshafener Str. 4a
82205 Gilching
Germany
T +49 (0) 8153 - 92 15 - 100
F +49 (0) 8153 - 92 15 - 319
info@torqueedo.com

Torqueedo France

T +33 (0) 240 - 010 604
france@torqueedo.com

Torqueedo Spain / Portugal

T +34 609 38 50 44
iberia@torqueedo.com



Torqeedo products are engineered and manufactured to the highest quality standards. Torqeedo motors and accessories are designed for long use in difficult conditions and must prove this in testing in continuous use. Every single product is carefully inspected before delivery. Certification to the internationally recognised quality management standard ISO 9001 is a guarantee of the quality of our products.

Imprint:

Editorial team: Christoph Ballin, Tess Smallridge
Concept: Eva Flamme, Maja Berger
Graphics design: Eva Flamme
Photography: Christian Brecheis, Hans Zeegers, Reinhard Dirscherl, Matt Knighton
Product photography: Sandra Eckhardt, Jan Ott
Industrial design: Schlagheck Design
Printer: AZ Druck und Datentechnik GmbH

 Torqeedo service center

 Torqeedo service partners –
You can find a complete list at www.torqeedo.com > Service centers

TORQEEDO

SERRY
JACHTWERF



Oud-Loosdr. dijk 249 a-d
1231 LX Loosdrecht
Holland
Tel. 035-58 234 04
Fax 035-58 260 80
info@serry.com
www.serry.com

Your Torqeedo dealer



This catalogue is printed on chlorine-free paper sourced from exemplary forestry.

Goods are delivered exclusively according to our Terms of Sale and Delivery according to Torqeedo's current Terms and Conditions of Business. We reserve the right to make any changes including pricing at any time.